



VR2
Venue Remote
User Manual
Revision 1.3



www.nstaudio.com

© NST Audio Ltd 2024

EU Declaration of Conformity.....	3
Declaration of Conformity	4
Important Safety Instructions.....	5
Instructions De Securite Importantes.....	6
WEEE.....	7
ROHS	7
Additional Warnings	7
Thank You	8
Key Features	8
Installation Instructions.....	9
Wall Template for Mounting the VR2	10
Concept Of VR2 Operation	11
Setting up the VR2	12
Physical VR2 controls.....	14
VR2 Control Pages in Detail	15
Preset Recall	16
Gain Change.....	17
Routing Change.....	18
Source Select	19
IP Commands.....	20
VR2 Configuration Settings – Customise Operation.....	21
Preset Sheduling – Automatic Timed Preset Recall.....	23
Adding Users and Permissions.....	24
Offline Set-up and Download	26
Static IP Addressing	27
FAQs (Frequently Asked Questions)	41
Technical Specifications.....	42
Maintenance.....	43
Servicing.....	43
Warranty.....	43
Contact.....	43

EU DECLARATION OF CONFORMITY

This declaration is issued under the sole responsibility of the manufacturer.

We:

NST Audio Ltd.
Unit 4C Seph Way
York Road Industrial Park
Malton
North Yorkshire
YO17 6YF
United Kingdom

Declare that this declaration of conformity is issued under our sole responsibility and belongs to the following product:

Model: VR2
Intended Use: Control Unit

The object of the declaration is in conformity with the relevant Union harmonisation legislation:

2014/35/EU Low Voltage Directive (LVD)
2014/30/EU Electromagnetic Compatibility Directive (EMC)

The following harmonised standard and technical specifications have been applied:

EN 62368-1:2014 - Audio/video, information and communication technology equipment - Safety requirements
EN 55032:2015 - Electromagnetic compatibility of multimedia equipment - Emission requirements
EN 55035:2017 - Electromagnetic compatibility of multimedia equipment - Immunity requirements

Signed:



Name: Dan Cartman

Position: Research and Development Manager

Date: August 2023



DECLARATION OF CONFORMITY

This declaration is issued under the sole responsibility of the manufacturer.

We:

NST Audio Ltd.
Unit 4C Seph Way
York Road Industrial Park
Malton
North Yorkshire
YO17 6YF
United Kingdom

Declare that this declaration of conformity is issued under our sole responsibility and belongs to the following product:

Model: VR2
Intended Use: Control Unit

The object of the declaration is in conformity with the relevant statutory requirements:

2016 No. 1101 - Electrical Equipment (Safety) Regulations 2016
2016 No. 1091 - Electromagnetic Compatibility Regulations 2016

The following UK designated standards and technical specifications have been applied:

BS EN 62368-1:2014 - Audio/video, information and communication technology equipment - Safety requirements
BS EN 55032:2015 - Electromagnetic compatibility of multimedia equipment - Emission requirements
BS EN 55035:2017 - Electromagnetic compatibility of multimedia equipment - Immunity requirements

Signed:



Name: Dan Cartman

Position: Research and Development Manager

Date: August 2023

**UK
CA**

IMPORTANT SAFETY INSTRUCTIONS

CAUTION: RISK OF ELECTRIC SHOCK. DO NOT OPEN.



The lightning flash with arrowhead symbol within an equilateral triangle is intended to alert the user to the presence of uninsulated "dangerous voltage" within the product's enclosure that may be of sufficient magnitude to constitute a risk of electric shock to persons.



The exclamation point within an equilateral triangle is intended to alert the user of important operating and maintenance (servicing) instructions in the literature accompanying the appliance.

WARNING: To prevent injury, this apparatus must be securely attached to the rack in accordance with the installation instructions.

- 1 : Read these instructions.
- 2 : Keep these instructions.
- 3 : Heed all warnings.
- 4 : Follow all instructions.
- 5 : Do not use this apparatus near water.
- 6 : Clean only with a dry cloth.
- 7 : Do not block any ventilation openings, install in accordance with the manufacturer's instructions.
- 8 : Do not install near any heat sources, such as radiators, heat registers, stoves or other apparatus (including amplifiers) that produce heat.
- 9 : Protect the power cord from being walked on or pinched particularly at plugs, convenience receptacles and the point where they exit from the apparatus.
- 10 : Only use attachments/accessories specified by the manufacturer.
- 11 : Unplug this apparatus during lightning storms or when unused for a long period of time.
- 12 : Refer all servicing to qualified service personnel. Servicing is required when the apparatus has been damaged in any way, such as if the power-supply cord or plug is damaged, liquid has been spilled or objects have fallen into the apparatus, the apparatus has been exposed to rain or moisture, does not operate normally, or has been dropped.
- 13 : Do not expose this equipment to dripping or splashing and ensure that no objects filled with liquids, such as vases, are placed on the equipment.

ATTENTION: RISQUE DE CHOC ELECTRIQUE. NE PAS OUVRIR.



Le symbole représentant un éclair fléché dans un triangle équilatéral a pour but d'alerter l'utilisateur de la présence d'une "tension dangereuse" non isolée à l'intérieur du boîtier, pouvant être d'une force suffisante pour constituer un risque d'électrocution.



Le point d'exclamation dans un triangle équilatéral a pour but d'alerter l'utilisateur de la présence d'instructions importantes concernant le fonctionnement et la maintenance, dans la documentation qui accompagne l'appareil.

ATTENTION: Pour éviter toute blessure, cet appareil doit être solidement fixé à la torture, conformément aux instructions d'installation.

- 1 : Lisez ces consignes.
- 2 : Conservez ces consignes.
- 3 : Respectez tous les avertissements.
- 4 : Respectez toutes les consignes d'utilisation.
- 5 : N'utilisez jamais l'appareil à proximité d'un liquide.
- 6 : Nettoyez l'appareil avec un chiffon sec.
- 7 : Veillez à ne pas empêcher la bonne ventilation de l'appareil via ses ouïes de ventilation. Respectez les consignes du fabricant concernant l'installation de l'appareil.
- 8 : Ne placez pas l'appareil à proximité d'une source de chaleur telle qu'un chauffage, une cuisinière ou tout appareil dégageant de la chaleur (y compris un ampli de puissance).
- 9 : Installez le cordon d'alimentation de telle façon que personne ne puisse marcher dessus et qu'il soit protégé d'arêtes coupantes.
- 10 : Utilisez exclusivement des accessoires et des appareils supplémentaires recommandés par le fabricant.
- 11 : Débranchez l'appareil de la tension secteur en cas d'orage ou si l'appareil reste inutilisé pendant une longue période de temps.
- 12 : Les travaux d'entretien de l'appareil doivent être effectués uniquement par du personnel qualifié. Aucun entretien n'est nécessaire sauf si l'appareil est endommagé de quelque façon que ce soit (dommages sur le cordon d'alimentation ou la prise par exemple), si un liquide ou un objet a pénétré à l'intérieur du châssis, si l'appareil a été exposé à la pluie ou à l'humidité, s'il ne fonctionne pas correctement ou à la suite d'une chute.
- 13 : N'exposez pas cet équipement au fait de tomber goutte à goutte ou au fait d'éclabousser et garantisiez qu'aucun objet rempli des liquides, comme les vases, n'est placé sur l'équipement.

WEEE



Once your NST Audio product has reached the end of its useful life, please ensure that is recycled in a proper manner.

"The WEEE Regulations 2013 are the UK interpretation of the EU WEEE Directive and aim to reduce the quantity of waste electrical and electronic equipment (WEEE) disposed of in the UK".

EEE producers are required to pay for the reuse, recycling and recovery of the products by registering as an EEE producer which requires them to join a producer compliance scheme.

NST Audio has been registered with producer compliance scheme Comply Direct since 2015 ensuring 100% compliance with the WEEE regulations 2013.

Our WEEE Producer Registration Number is WEE/HG5453ZY.

Old electrical equipment can be recycled along with its metal enclosure. Our products are marked with a crossed-out wheeled bin symbol on the rear of the product.

Please do not throw any electrical equipment (including those marked with the crossed out wheeled bin symbol) in your general waste bin.

NST Audio Ltd. is able to arrange WEEE collections for our customers through a trusted network of WEEE recycling facilities made available by Comply Direct. We are able to arrange collection and transportation of your WEEE to reprocess and recycle ensuring the minimum goes to landfill.

ROHS

The Restriction of Hazardous Substances in Electrical and Electronic Equipment (RoHS) Directive (2011/65/EU).

NST Audio Ltd products are RoHS compliant, and are available for export as lead-free and RoHS compliant.

NST Audio Ltd is committed to eliminating the use of hazardous substances in the materials, manufacturing and packaging of our products in strict accordance with the RoHS directive.

With regards to the RoHS Directive 2002 / 95 / EC of the European Parliament and of the Council of 27 January 2003 on the restriction of the use of certain hazardous substances in electrical and electronic equipment, we declare that to the best of our knowledge, all products meet and fulfil all the requirements of the aforementioned directive.

ADDITIONAL WARNINGS



只有在高海拔地区使用不超过2000米。

ONLY TO BE USED AT ALTITUDE BELOW 2000 METRES



只适合于非热带气候地区使用

ONLY TO BE USED IN NON-TROPICAL CLIMATE REGIONS

THANK YOU

Thank you for choosing an NST Audio product for your application. Please spend a little time reading through this manual, so that you can obtain the best possible performance from the unit.

All NST products are carefully designed and engineered for cutting-edge performance and world-class reliability. If you would like further information about this, or any other NST product, please do not hesitate to contact us.

UNPACKING THE UNIT

After unpacking, please check the unit carefully for any damage. If any is found, immediately notify the carrier concerned - you, the consignee, must instigate any claim.

Please retain all packaging, in case of future re-shipment.

KEY FEATURES

- Height, depth and width specifications are shown below
- Screen: Colour 240 x 320 pixel LCD
- Bezel side illumination: fully programmable RGB lighting on the long sides of the body
- Controls: touch screen and 1 rotary control
- Comms and power: Standard RJ45 Ethernet port, requiring 48V PoE (Power Over Ethernet)
- Real time clock and calendar (RTC): battery backed for a minimum of 2 weeks after 8 hours continuous charge
- All configuration settings stored in non-volatile memory (not affected by RTC battery level)

NOTE: We have tested the VR2 with a Netgear GS108PE and recommended the use of this PoE router.

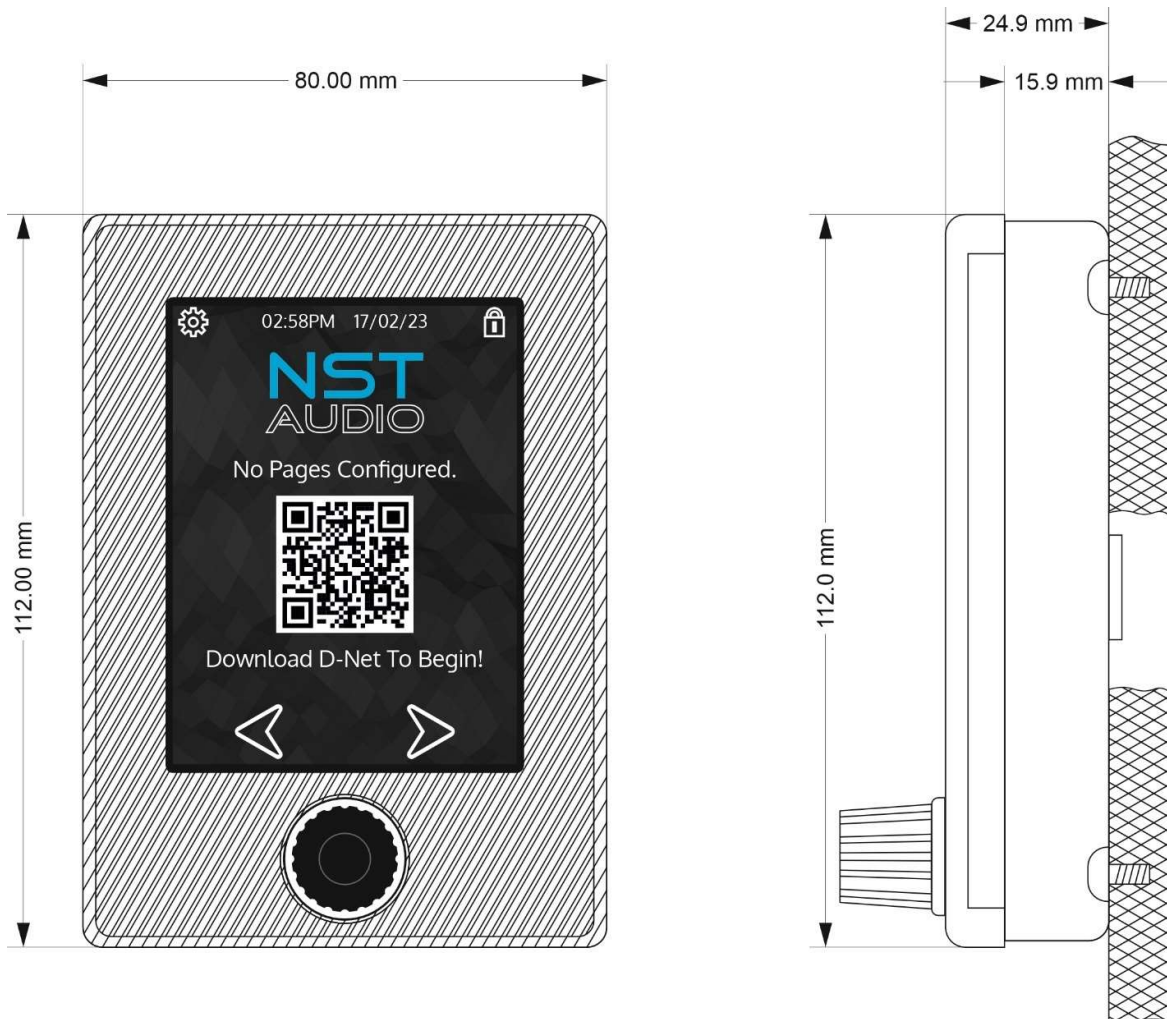

INSTALLATION INSTRUCTIONS

The VR2 wall panel control is designed to fit into the provided bracket, and is secured with two countersunk screws into the top and two underneath at the bottom (supplied). The bracket is surface mounted onto the wall with four screws. Please use the template overleaf to position screw holes. Please use the screws provided to secure the bracket to the wall to ensure that the VR2 will fit into the bracket correctly.

Note that the top and bottom holes (assuming portrait mounting) are spaced to align with US single gang light switch/socket back boxes (83mm spacing). The other two holes (60mm spacing) are spaced to align with UK or EU single gang light switch/socket back box.

The VR2 will also require a hole in the wall with sufficient size to accommodate the network socket and sufficient depth to accommodate the network cable. Be aware that network cables are variable in their depth requirements – our recommendation is at least 50mm behind the wall surface to ensure that the cable is not bent beyond its specification.

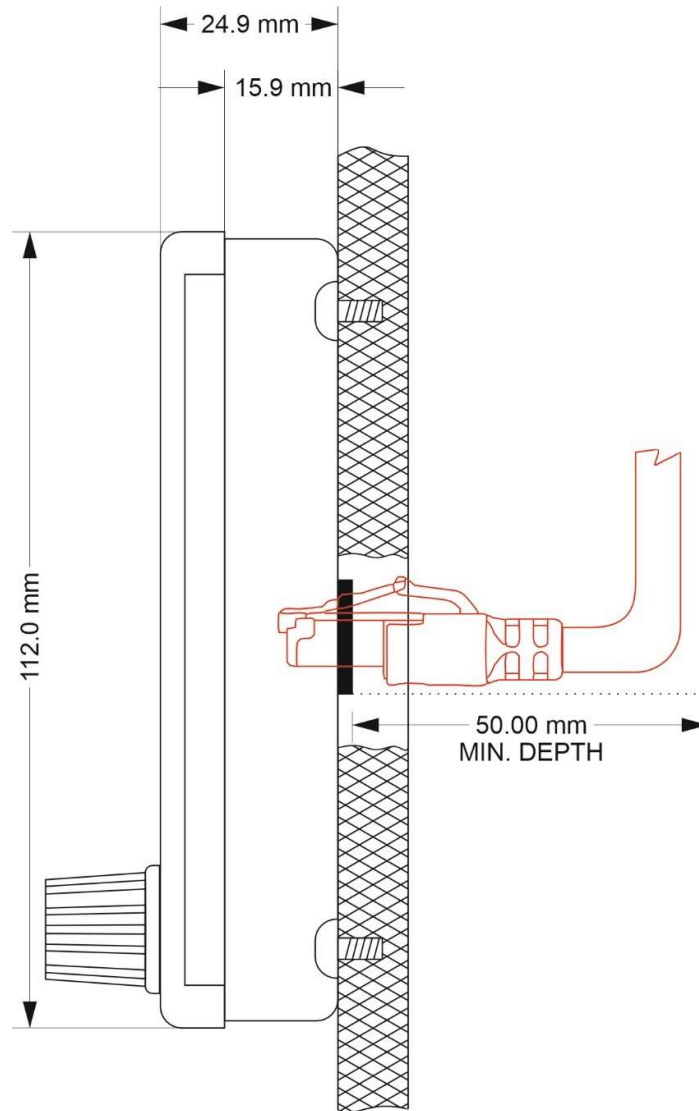

PRINT AT FULL SIZE!
DO NOT SCALE TO FIT PAGE IF PRINTING FROM A PDF
CHECK AGAINST THE 30mm MEASUREMENT BEFORE USING TO MARK HOLES!

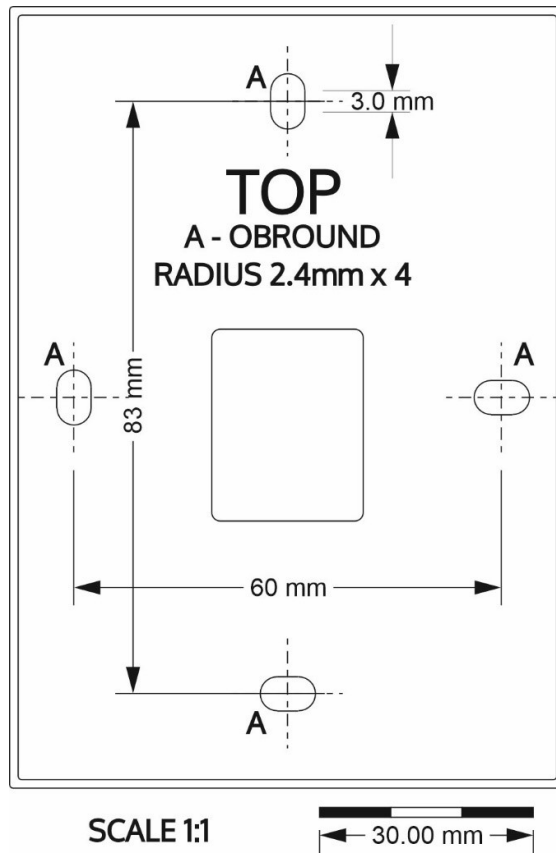

PRINT AT FULL SIZE!
DO NOT SCALE TO FIT PAGE IF PRINTING FROM A PDF
CHECK AGAINST THE 30mm MEASUREMENT BEFORE USING TO MARK HOLES!

CONCEPT OF VR2 OPERATION

The VR2 initially powers up with no control pages configured. The QR Code shown on-screen takes you to the software page on the NST Audio website to download a copy of D-Net and get started.

The screen can display two panes side by side, and these panes can have a variety of system functions, namely:

- 1) Preset recall (page 15) – define a scene change on a single device or choose different presets to recall simultaneously on different devices on the system. The purpose of the pane's recall can be labelled to reflect its overall use, such as "Morning", "Evening" or "All Mute". Note that this feature can now be automated using timed presets – see page 23 for more information.
- 2) Gain control (page 17) – define a single control that will adjust the level of either a single fader or gain control anywhere on the system, or up to 50 points simultaneously. These can be input or output faders, or mix matrix controls. The gain settings is absolute (so all controls chosen to adjust will be set to the same value), and the range, step size and readout units can be configured to suit.
- 3) Mutes/Routes (page 18) – in the same way as gain controls may be defined for any single fader or gain control anywhere on the system, single or multiple mutes can be simultaneously enabled or disabled on a single control using this pane. Note that it is NOT a toggle action – it will set all controls configured to a single state. To reverse this action, define a second pane with the states reversed.
- 4) Source Select (page 19) – a quicker way to manipulate input matrix settings to switch between different inputs. Up to four source selections can be combined on a single pane and multiple outputs across different devices can all have their matrix gains enabled simultaneously. All other matrix gains for that output will be automatically muted.
- 5) IP Commands (page 20) – Control OEM equipment with up to three buttons on a single pane. Set up predefined commands to be sent when pressing a button, with support for both UDP and TCP protocols.

As panes are added to the VR2, they will appear in real time, and there is no "save" procedure required. This configuration information is stored indefinitely in the VR2. Multiple VR2 panels (and VR1 panels) can be configured to operate in a single venue with different sets of control panes defined.

It is also possible to set up different user levels (up to 10) and protect each with a 6 digit PIN code. Each user can be granted access to any or all defined panes, and this system can be used for either "vertical" security control (so users' permissions based on seniority) or "horizontal" control (so, creating users to group controls, such as a "Lobby" user only seeing volume and source select for the Lobby, with or without a PIN). This is explained on page 23.

The VR2 can be configured "offline" and the configuration downloaded at the time of installation. This, of course, depends on the other devices on the network being predefined as well, with the controls and channels named/memories saved. Offline configuration is explained on page 26.

SETTING UP THE VR2

To set-up the VR2, a computer running either Microsoft Windows or Apple Mac OS with D-Net installed, will be required, along with a network switch / router, capable of providing PoE (Power Over Ethernet) and CAT5 (or greater) Ethernet cable.

D-Net is available to download from the NST Audio website: [Software – NST Audio](#)

Save the downloaded file to a known location on your computer and install the software from there by double-clicking on it. Read and follow the on-screen instructions to complete the installation.

The iPad version of D-Net is available from the Apple app store. (There is a link to this from the software page URL shown above).



The remainder of this manual assumes you have some prior knowledge of using D-Net - if you are unfamiliar with the D-Net software, a user manual is available from the NST Audio website.

CONNECTING TO THE VR2

Once everything is connected and online, the VR2 remote will appear alongside the other NST Audio processors on the network, in D-Net's 'Virtual Rack', as shown in the example below:

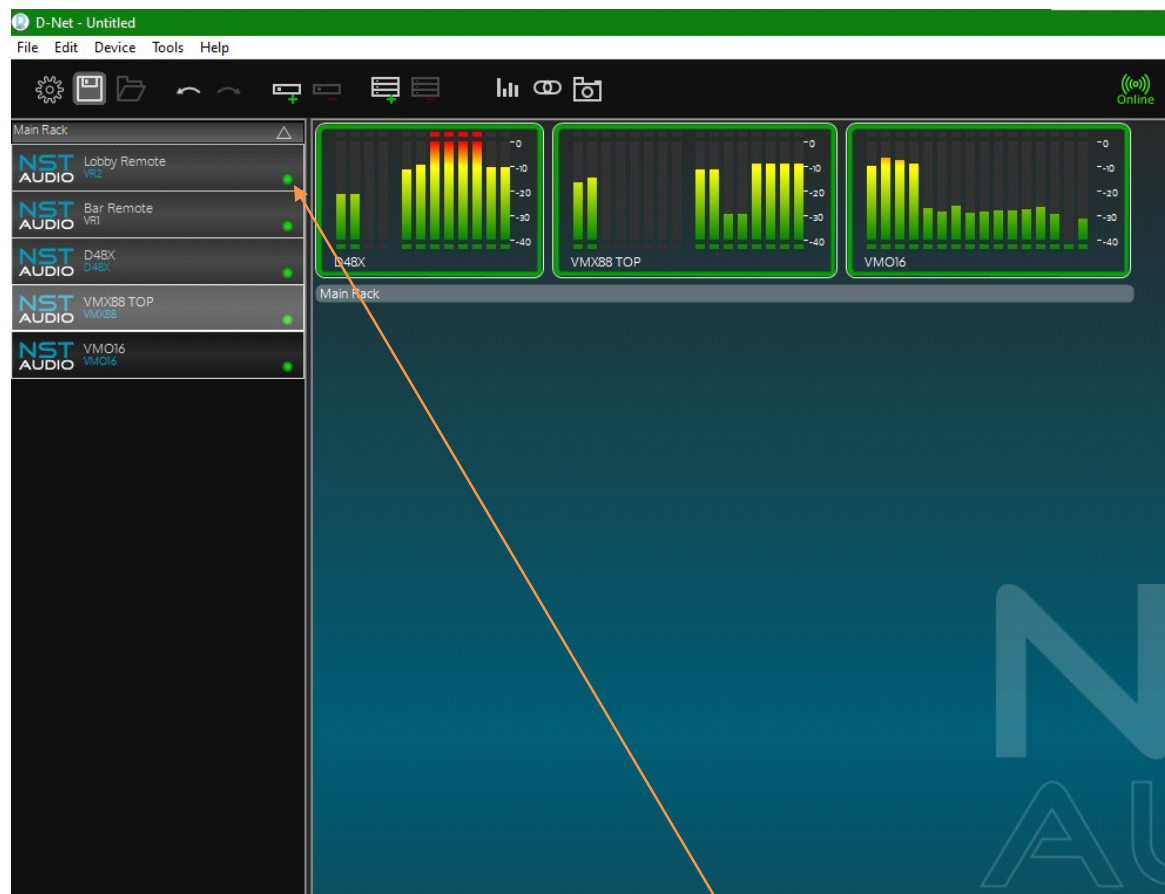

To access the VR2's control panel, simply double click / tap the VR2 device on the left. This will open the VR2's control panel, to allow initial set-up or editing of an existing device.

VR2 CONTROL PAGE OVERVIEW

On initial power-up, depending on your geographical region (and how long the VR2 has been powered down¹) the clock at the top of the VR2's screen may not show the correct time. D-Net compares the time displayed on the VR2 against the time setting of the PC, and will show an alert and message if the time needs setting (plus a warning icon on the VR2 status bar). Press the "Set Time" button that will be displayed to correct this. The button will disappear once the time is set.

Make sure to check the daylight savings time if it is used in your region, and choose the correct time zone. (If you are not using timed presets, this is not crucial, but this may affect the trigger times if you are.)

The initial VR2 control page will look similar to the example below – more options appear upon adding panes:

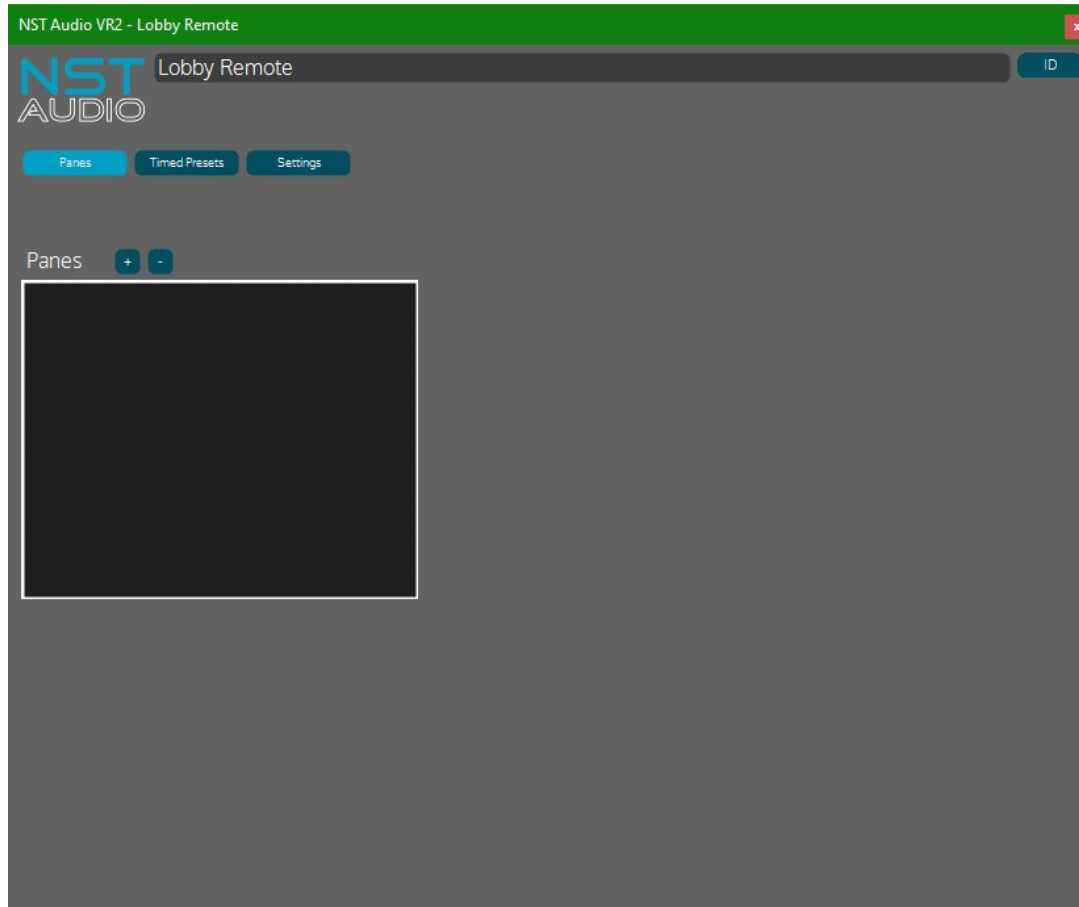

Device Name: Double click the device name to rename the VR2 – this name is also shown on the settings screen of the VR2.

ID Button: Press to make the physical VR2 panel flash for five seconds. This feature is useful for identifying a VR2 if more than one is installed in the same venue.

Panels Button: The controls that the VR2 shows are built from a blank workspace as a series of "panes" (as two can be displayed side by side). Pressing the "+" button will pop-up a list of the various pane types that can be created. See page 15 for the detailed explanation of each type of pane and what it can control.

Timed Presets Button: The VR2 has a real time clock and calendar (with daylight savings time compensation). This can be used to trigger reoccurring memory recalls. For example, to reset the system back to known defaults every morning, or to control EQ or levels via preset recalls at various points in the day/evening. See page 23 for more information on how to configure this,

Settings Button: get device specific information about IP and MAC address, and check the firmware revision. The orientation of the VR2 can also be chosen (landscape L or R, or portrait) and the default bezel illumination colour chosen, as well as timers relating to how the VR2 behaves when not being used. See page 21 for a rundown of all of these customisations including locking the D-Net adjustments and uploading a custom screensaver.

¹ The VR2 can maintain its clock for a minimum of 2 weeks after power has been applied for 8+ consecutive hours. All configuration settings are backed up indefinitely.



Once the VR2 has been set-up, using D-Net, the panel is operated by using the single rotary control and the touch screen.

The brightness of the display and the bezel LEDs can be adjusted by accessing the 'Settings' page, by pressing the cog icon in the top left corner of the display. To exit the Settings, simply press either of the on screen arrow buttons.



To lock the VR2, or get back to the user selection screen, press the padlock/home² icon in the top right corner of the display.

NOTE: The VR2 will go into standby mode, when it is not being used. The device is functioning perfectly normally, and will immediately 'wake-up' when up when the screen is touched. This feature is designed to save power, and also to extend the life of the LCD display and LEDs.

The bezel illumination can be left illuminated at half the user set brightness to help locate the device in dark environments and to aesthetically match a venue colour scheme. See page 21 for the explanation of all the customisation options available for the VR2.

² The top right icon will be a home symbol if current user has no PIN, or a padlock icon if a PIN is set for the current user.

VR2 CONTROL PAGES IN DETAIL

Check out a full suite of VR2 quick training videos on our Youtube Channel - Just search "NST Audio VR2"



VR2 - Touch Venue Remote: Controlling OEM Equipment with IP Commands

NSTAudio
52 subscribers

26 views 5 days ago
A VR2 can control other equipment via the IP Control pane. We set up some buttons on a VR2 to control functions on an EPSON projector. A detailed explanation of this procedure is on our website at nstaudio.com/vr2_downloads ...more

0 Comments Sort by

- From NSTAudio Consumer Electronics
- VMX88L System Setup NSTAudio 238 views · 6 months ago
- What's in a VM016? NSTAudio 76 views · 4 months ago
- What's in a VMX88? NSTAudio 150 views · 4 months ago
- Creating a 16x16 Matrix using a pair of VMX88s and Dante NSTAudio 419 views · 5 months ago
- ID48X - 180 Second Build NSTAudio 388 views · 8 months ago
- VR2 - Touch Venue Remote: Adding Source Select Lists NSTAudio 16 views · 3 weeks ago
- VR1 PoE Remote Wall Panel - Adding Source Selects NSTAudio 151 views · 2 years ago
- D-Net Tips Compilation NSTAudio 380 views · 2 years ago
- VR2 - Touch Venue Remote: Adding Preset Recall Panes NSTAudio 15 views · 3 weeks ago

Scan the QR code by each section in this manual to go directly to the related video.

Preset Recall

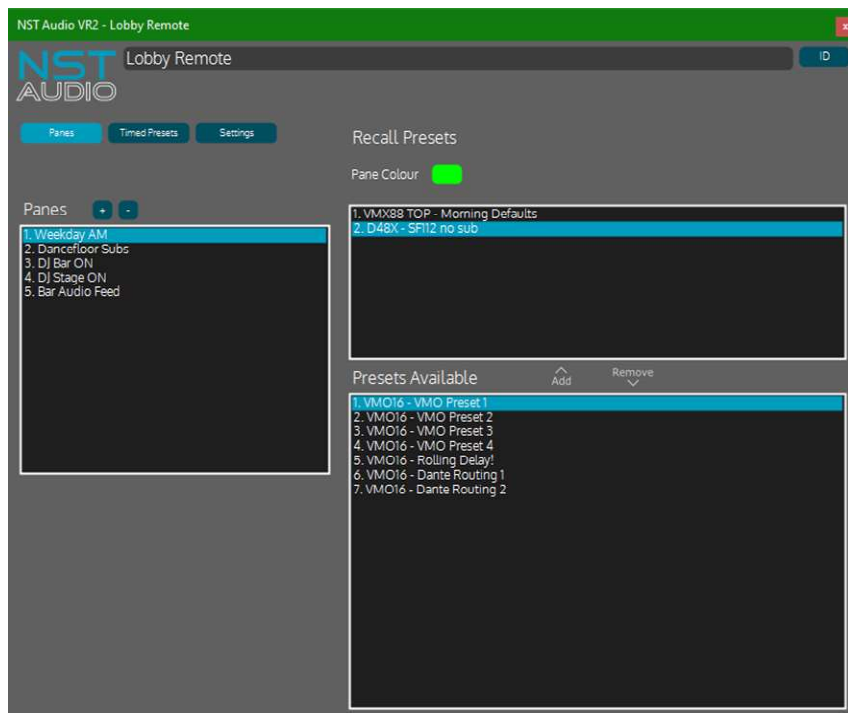

Available presets, from all devices, will be shown in the Presets Available window.

Select a preset to be included in this page and use the Add/Up button to add it. The preset will then appear in the Recall Presets window above.

Add additional presets, from other devices, by repeating this process.

Note that adding a preset from a device will immediately remove all the remaining preset choices from that device, as of course it's not possible to recall two preset from one device. If you have added the wrong preset, just highlight it and use the Remove/Down button to remove it and the list for that unit will reappear.

All presets contained within the Recall Presets window will recall simultaneously, from a single pane shown on the VR2's display.

Rename the pane title to something more useful by double clicking on it in the Panels window, and choose the accent colour which changes the title underline and the button text colour on the VR2 (and bezel colour is configured to follow – see settings on page 21 for how to change this).

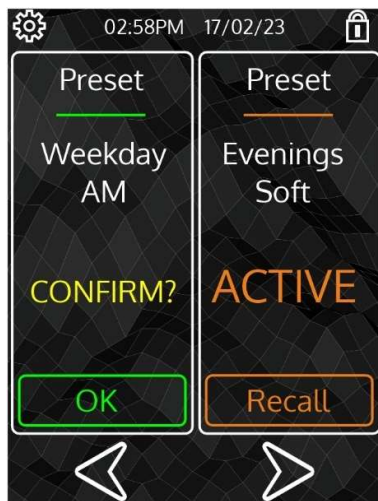

Note that the panes' order can be rearranged by clicking, holding and dragging them, so they can be grouped to appear in a more logical order depending on use – for example, "Dancefloor Subs" and "Bar Subs" gains beside each other, or a preset recall and a single gain control for a VIP area.

On the VR2, press the Recall button and a confirmation message will be shown – press OK and the preset will recall. "ACTIVE" will be displayed on the preset that was last recalled via this VR2.



Gain Change

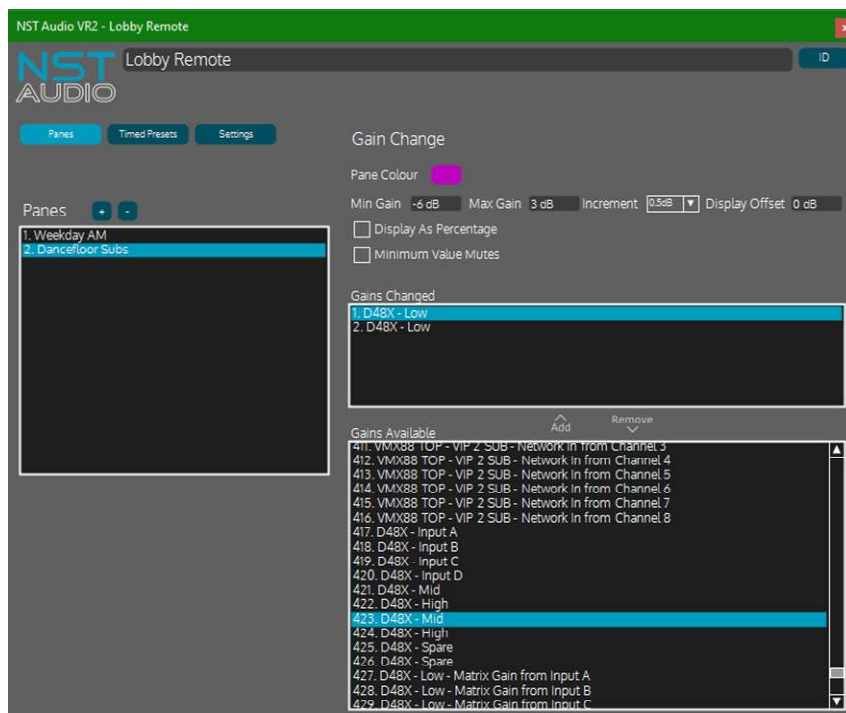

Available channel gains, from all devices, will be shown in the Gains Available window.

Select a gain control to be included in this pane and use the Add/Up button to add it. The gain parameter will then appear in the Gains Changed window above.

Add additional gains, from other devices, by repeating this process.

All gain parameters contained within the Gains Changed window will adjust simultaneously, from a single pane shown on the VR2's display. Note that all gain adjustments are absolute.

The readout can be additionally adjusted by setting max and min range values, and the step size for changes, plus the ability to add an offset to the displayed value, or just display the range as a percentage instead of a dB value.

Note that adding matrix gains to a gain control will limit the max gain value to 0dB (matrix gains cannot go above 0dB).

Ticking the "Minimum Value Mutes" option allows the gain to be reduced below the minimum setting to -100dB (effectively a mute).

Rename the pane title to something more useful by double clicking on it in the Panes window, and choose the accent colour which changes the title underline and the button text colour on the VR2 (and bezel colour is configured to follow – see settings on page 21 for how to change this).

Note that the panes' order can be rearranged by clicking, holding and dragging them, so they can be grouped to appear in a more logical order depending on use – for example, "Dancefloor Subs" and "Bar Subs" gains beside each other, or a preset recall and a single gain control for a VIP area.

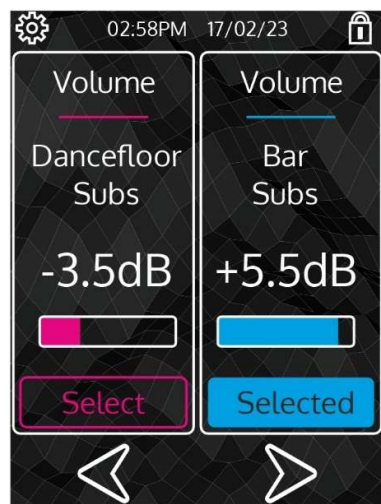

On the VR2, if two gain controls are shown side by side, use the select buttons to decide which one will be adjusted by the rotary.

Moving the gain control off-screen will automatically deselect it, so it can't be adjusted accidentally.



Routing Change

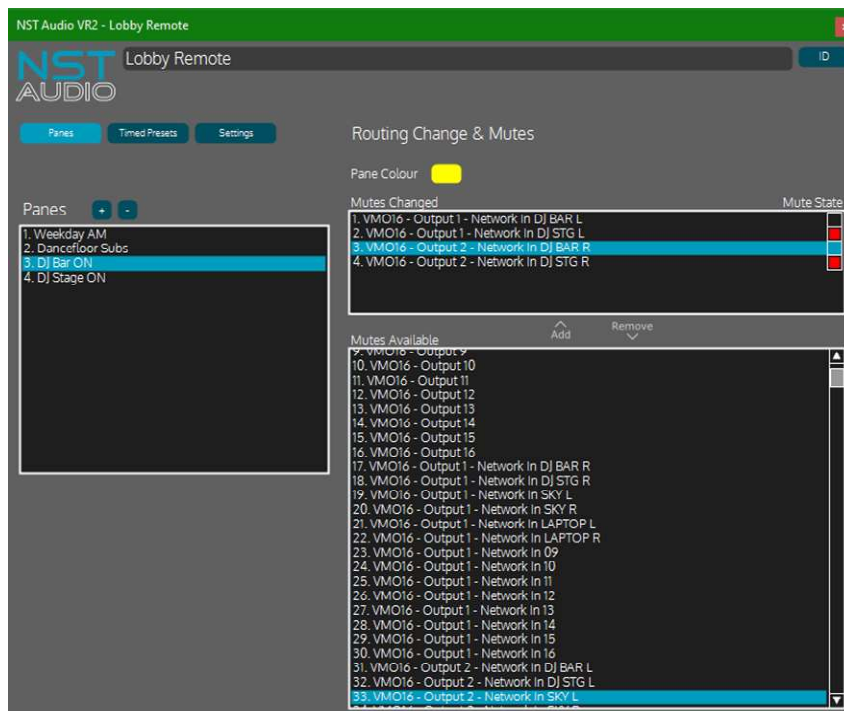

Available mutes, from all devices, will be shown in the Mutes Available window.

Select a routing or mute section to be included in this page and use the Add/Up button to add it. Choose, for each mute point, whether the mute is to be enabled or not, by checking the Mute State on the right hand side of the Mutes Changed window.

The mute will then appear in Mutes Changed window above. Add additional parameters, from other devices, by repeating this process.

Remember that this is not a toggle action control – if you want to swap back to the other state, you need to add a second routing change pane with these mute points reversed.

In the example shown, we are swapping between two DJ mixers on two outputs of a VMO16, using a pair of panes.

Rename the pane title to something more useful by double clicking on it in the Panes window, and choose the accent colour which changes the title underline and the button text colour on the VR2 (and bezel colour is configured to follow – see settings on page 21 for how to change this).

Note that the panes' order can be rearranged by clicking, holding and dragging them, so they can be grouped to appear in a more logical order depending on use – for example, "Dancefloor Subs" and "Bar Subs" gains beside each other, or a preset recall and a single gain control for a VIP area.

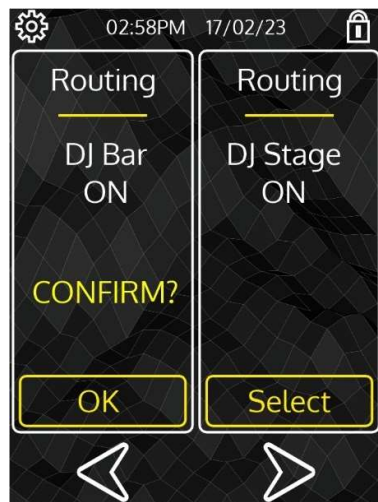
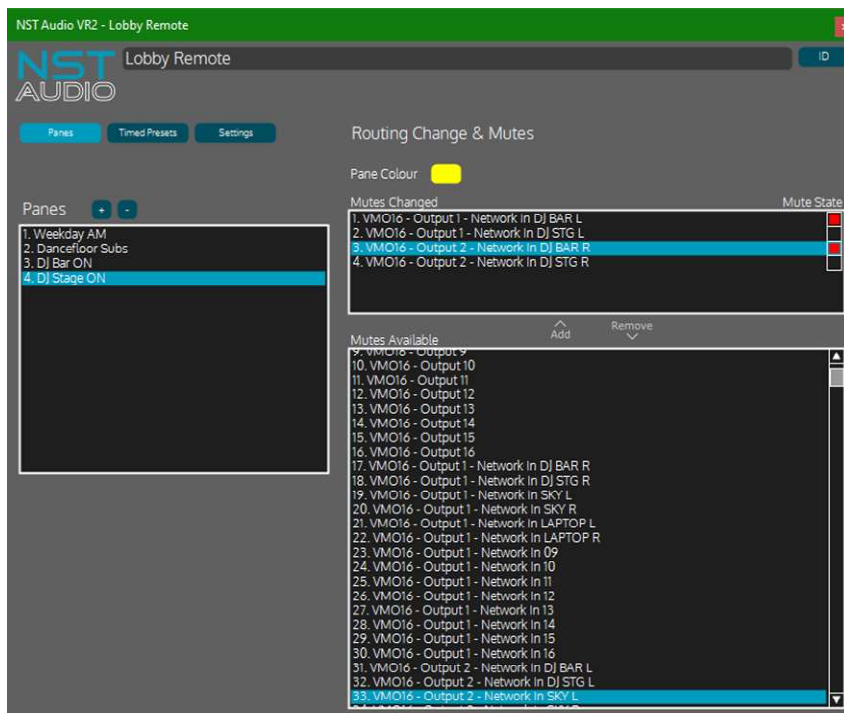

On the VR2, routing screens work virtually the same as preset recalls, except that after the confirmation query, the screen doesn't show an "ACTIVE" message.



Source Select

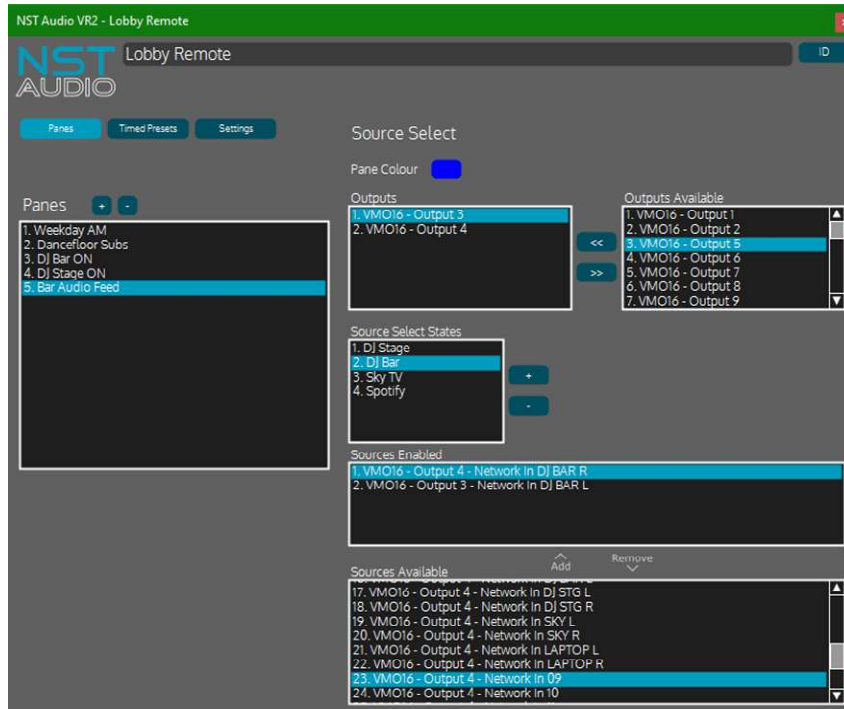

Start by creating the list of possible source selections you want on the page (max 4 per page) in the “Source Select States” window, and name these selections.

For each Source Select State, choose the outputs which will change and choose the matrix outputs to unmute for this state (**all other matrix feeds for this output will automatically be muted**).

Repeat the process for each Source Select State.

The final pane will have a list of the Source Select States which can be chosen, which will then in turn enable the sources from the Sources Enabled window.

Rename the pane title to something more useful by double clicking on it in the Panes window, and choose the accent colour which changes the title underline and the button text colour on the VR2 (and bezel colour is configured to follow – see settings on page 21 for how to change this).

Note that the panes’ order can be rearranged by clicking, holding and dragging them, so they can be grouped to appear in a more logical order depending on use – for example, “Dancefloor Subs” and “Bar Subs” gains beside each other, or a preset recall and a single gain control for a VIP area.



On the VR2, pressing “Select” enables the rotary to scroll through the sources that have been defined and pressing “Recall” will then switch the sources and highlight the choice.



Watch Sources set-up video

IP Commands

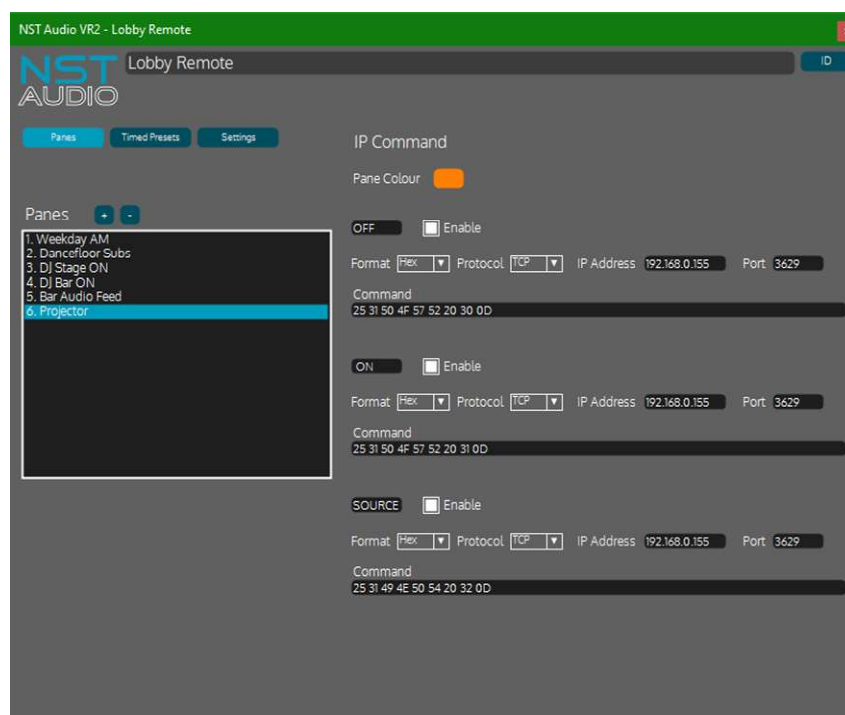

Up to three buttons can be enabled on a single pane. Setting up the commands for control of OEM devices will require prior knowledge as to their protocol and command sets. Please consult the individual manufacturer for more information.

For example, Epson, Casio and other Japanese projector manufacturers subscribe to a simple command protocol subset called "PJLink".

We have tested this feature with our own simple command protocol and IP controlled relay/switch boards.

Note that the button action is a momentary – the command string will be sent once each time the button is pressed.

Rename the pane title to something more useful by double clicking on it in the Panels window, and choose the accent colour which changes the title underline and the button text colour on the VR2 (and bezel colour is configured to follow – see settings on page 21 for how to change this).

Note that the panes' order can be rearranged by clicking, holding and dragging them, so they can be grouped to appear in a more logical order depending on use – for example, "Dancefloor Subs" and "Bar Subs" gains beside each other, or a preset recall and a single gain control for a lobby area.



On the VR2, the buttons will be shown numbered 1-3 from top to bottom. In this example they are grouped with a volume control for the lobby area.

If you see an error displayed on the VR2 after trying out your IP command – this is what to check/confirm in your D-Net configuration:

ERROR: 1 – Still sending message – this might happen if the button is pressed too many times in quick succession

ERROR: 2 – Too many TCP/IP connections open

ERROR: 3 – Timeout – message could not be sent as destination TCP address could not be found (check you've got the correct IP address specified for the receiver and that it's online)

ERROR: 4 – No command – the command string field is blank for this button (make sure you have entered a command for each button)



Watch IP control
set-up video

VR2 CONFIGURATION SETTINGS - CUSTOMISE OPERATION

The VR2 has many options designed to customise it for use in any setting. These include the uploading of a custom image for the screensaver, and control of the bezel lighting on the long sides of the body. Flexibility in the mounting orientation allows the screen to be turned to operate in both horizontal configurations, as well as vertical (portrait).

Multiple user levels may also be configured with individuals' access to any particular control panes granted or denied. This is covered in a separate section on page 23.

Individual pane colour choices may also be reflected in the operation of the VR2, so that adjustments can be grouped and tied in with particular colours. For example – making all changes for a part of a venue one colour to avoid mistakes (gains and presets for the bar are all green, and for the restaurant they are all pink...).

Alternately, the colours may be used to group types of control – all gains are blue, all mutes are red etc.

There are several timers that can be set to affect how the VR2 behaves when it's not being used – how long it waits before going to sleep, and how the bezel illumination behaves.

All of these options are accessed via the Settings button on the VR2 window.

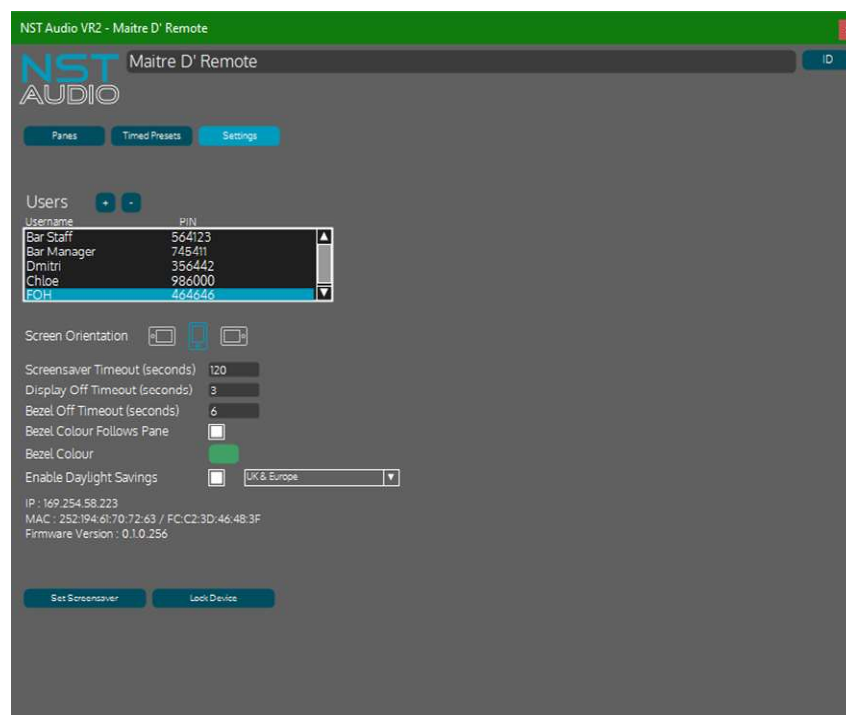

In addition to setting up users and security (covered on page 23), working down the options we have:

Screen orientation: Choose horizontal with the rotary control on the left or right, or portrait. The VR2 will update in real time as this is changed.

Screensaver Timeout: Set how long before the VR2 swaps to show the screensaver. Maximum time is 120 seconds.

Display Off Timeout: Set how long before the VR2 turns off the LCD and backlight once screensaver is shown. Maximum time is 120 seconds.

Bezel Off Timeout: Set how long the bezel illumination stays on after the display times out. Maximum time is 120 seconds, but setting this to 0 will leave the bezel illumination on for 2 minutes and then dim to 50% brightness.

Bezel Colour Follows Pane: When a panel control is selected or adjusted, the bezel colour will change to match that chosen for that pane. Individual bezel colours are chosen via the Panes configuration:



Bezel Colour: Sets the default colour of the bezel illumination when a pane is not selected and when the VR2 displays its screensaver. Set colour to black to disable completely.

Enable Daylight Savings: Choose the correct time zone for your geographical region to ensure the time and date are displayed correctly and that timed presets trigger at the correct hour.

Also shown are the VR2's IP address, MAC Address and current firmware version – this information is for technical support purposes and is read only.



Set Screensaver: The NST Logo shown when the VR2 displays the screensaver can be changed to match the venue's. The required file format is 24-bit RGB, in png format, with a max resolution of 320W x 320H pixels.

Note that the viewable area is 240W x 300H central for portrait orientation, and 320W x 220H central in landscape orientations.

Press "Set Screensaver" to open a file explorer and load the file.

A default logo is available on our website under downloads on the VR2 product page to restore this if necessary.

<https://nstudio.com/vr2/#downloads>

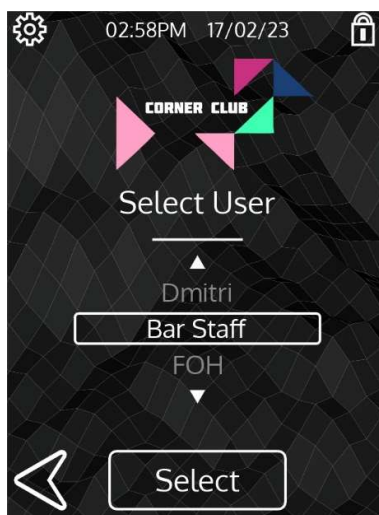

Set Logo : The NST Logo shown when the VR2 displays the user list³ can be changed to match the venue's. The required file format is 24-bit RGB, in png format, with a max resolution of 180W x 60H pixels.

Press "Set Logo" to open a file explorer and load the file.

A default logo is available on our website under downloads on the VR2 product page to restore this if necessary.

<https://nstudio.com/vr2/#downloads>

Lock Device: This locking mechanism is not related to the creation of user levels – this is to lock the VR2 from unauthorized configuration changes in D-Net. The PIN is stored in the VR2 and will prevent anyone downloading D-Net and connecting to gain access to the configuration.

There is no backdoor/master password so use this feature carefully!



³ User list will only be shown when more than one user has been defined with a non-zero PIN

PRESET SCHEDULING - AUTOMATIC TIMED PRESET RECALL

The VR2 has a real time clock and calendar (with daylight savings time compensation). This can be used to trigger recurring memory recalls. For example, to reset the system back to known defaults every morning, or to control EQ or levels via preset recalls at various points in the day/evening.

Configuration is via the Timed Presets button.

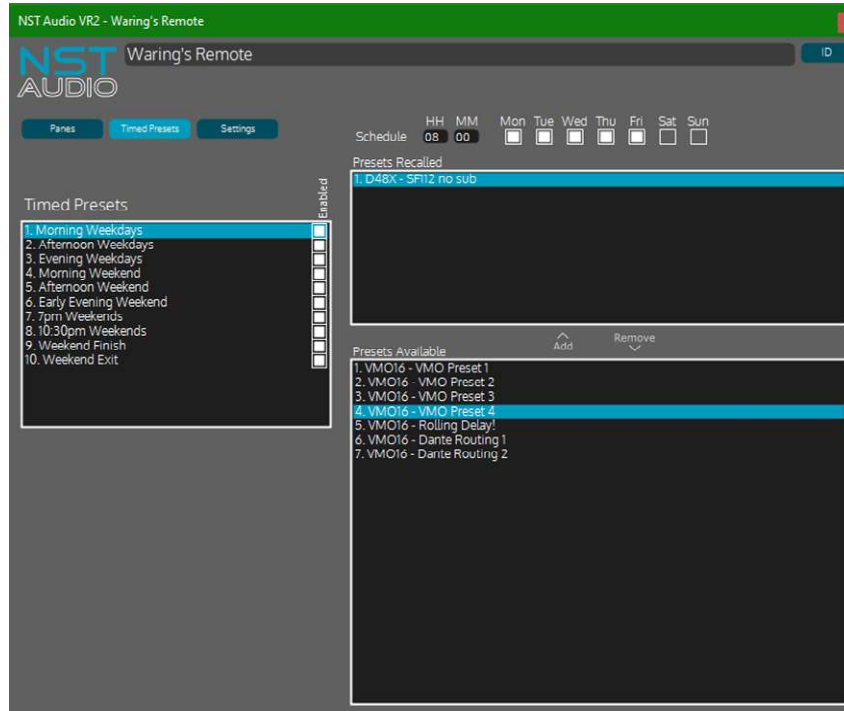

Set-up of timed presets is similar to creating a presets pane. First, enable one of the entries in the Timed Presets window to access available presets and the scheduler.

Select a preset to be included in this page and use the Add/Up button to add it. The preset will then appear in the Presets Recalled window above. Add additional presets, from other devices, by repeating this process.

Note that adding a preset from a device will immediately remove all the remaining preset choices from that device, as of course it's not possible to recall two preset from one device.

If you have added the wrong preset, just highlight it and use the Remove/Down button to remove it and the list for that unit will reappear.

For each timed preset there is also now the option to choose what days of the week and what time this presets associated with this schedule entry are to recall.

Up to ten scheduled entries can be defined. Rename the entry double clicking on it. These names do not appear on the VR2 but are stored in it and so retrieved when online via D-Net.

If any timed presets are enabled, the VR2 will display an alarm clock icon to the right of the settings cog icon beside the clock. Timed presets can be configured and viewed via D-Net.

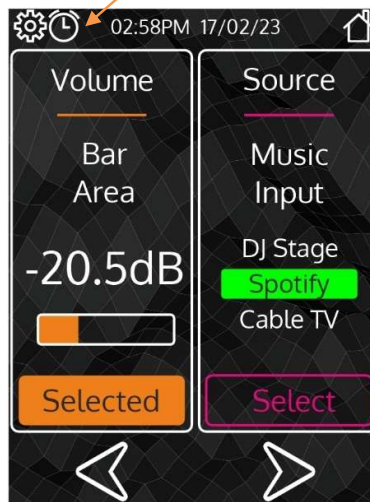

ADDING USERS AND PERMISSIONS

It is also possible to set up different user levels (up to 10) and protect each with a 6 digit PIN code. Each user can be granted access to any or all defined panes, and this system can be used for either "vertical" security control (so users' permissions based on seniority) or "horizontal" control (so, creating users to group controls, such as a "Lobby" user only seeing volume and source select for the Lobby).

Settings up users is via the Settings button.

Users are added by pressing the "+" button and giving them a name and PIN.

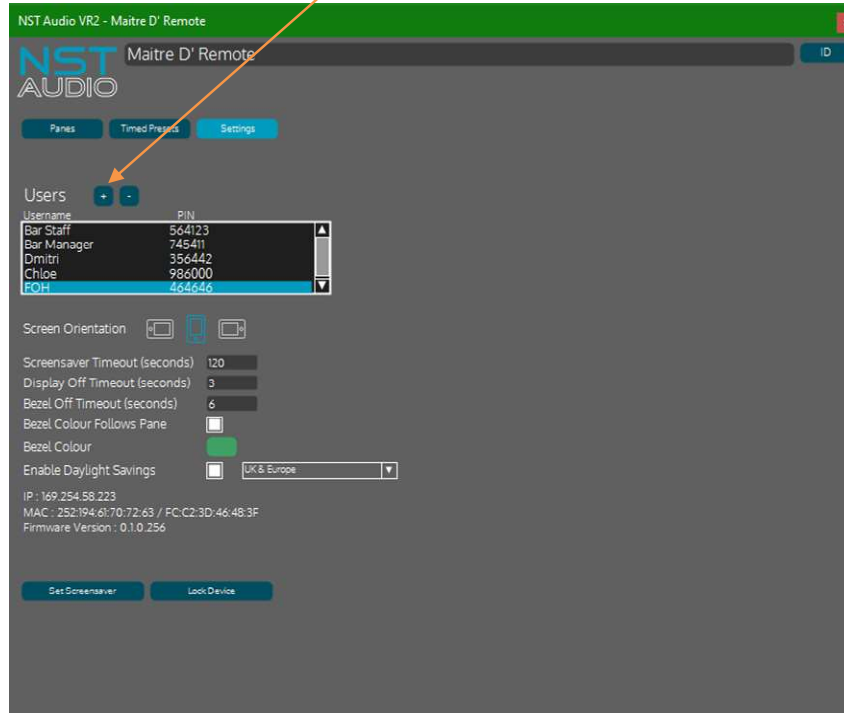

If the PIN is left at 000000 then they will appear in the user list but if selected will gain immediate access to control panes assigned.

If a PIN is non-zero, then this will need to be entered to grant access.

Once the Users list has been populated as required, any panes defined will now show the users listed, along with check boxes to individually grant access to each pane.

In this example, Bar Staff can only adjust the bar volume, whilst the Bar Manager has access to everything except the restaurant volume.

The FOH user can only adjust the restaurant volume, and Chloe and Dmitri (bar owners) can access everything.

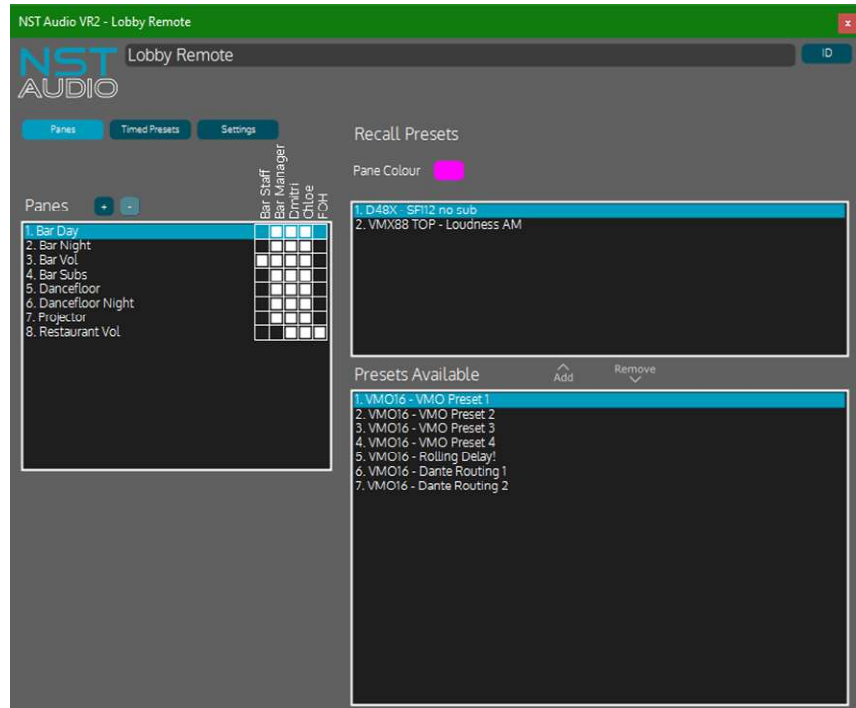



To switch between users, or to immediately lock the remote without waiting for the timeout to expire, press the padlock/home icon in the top right hand corner of the VR2's screen.

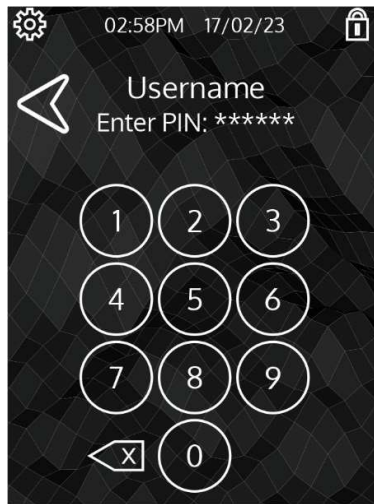

Use the rotary to choose the required user from the list and press "Select".

If there is a PIN code associated with the user, (000000 can be used if no PIN is required) a PIN entry screen will then be show. Type in the correct PIN to access this user's control.

The top right icon will be a home symbol if current user has no PIN, or a padlock icon if a PIN is set for the current user.

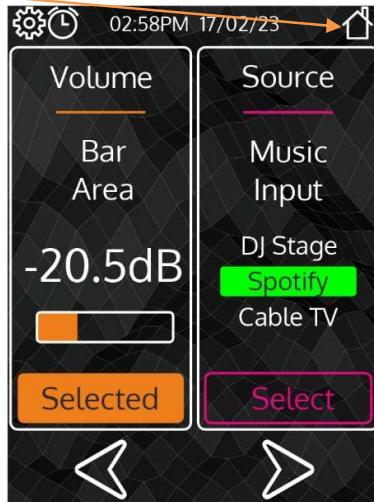

OFFLINE SET-UP AND DOWNLOAD

A VR2 can be configured completely off-line, along with other processors on a system. To set up control panes with the correct parameters (presets to recall, gains and mutes to adjust), obviously either the other system components will need to have been created alongside the VR2 (and presets saved in the offline configuration) if D-Net is going to be able to populate the lists of controls.

Alternately, go online to a live system and save this file for later use offline, with the ability to then add a VR2 and work with what was previously saved.

In either case, once the VR2 has been configured and it's required to connect to the live system, D-Net will wait until a VR2 is discovered, and then will offer to match the live remote with the offline configuration.

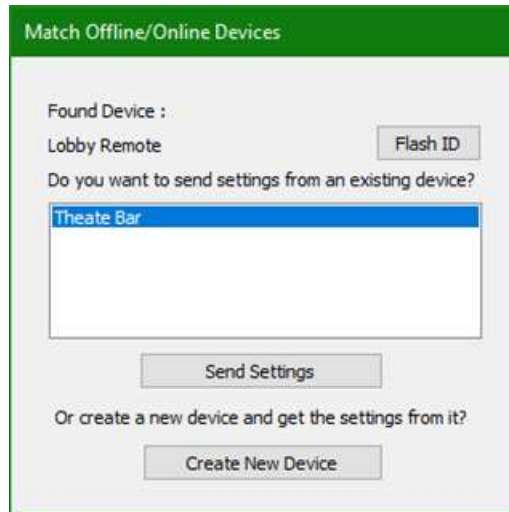

Press the Flash ID button to check which live VR2 is going to receive the settings. It will flash the NST logo and bezel in blue for five seconds. This is useful if there are multiple VR2s on the system.

If you are satisfied this is the correct remote, pressing the "Send Settings" button will sync the VR2 with the configuration in D-Net.

Alternately, create a new online device and then copy/paste from the offline one into the online one, and delete the original offline version.

To access copy/paste, open both devices (the online and offline ones) and right click on the window...

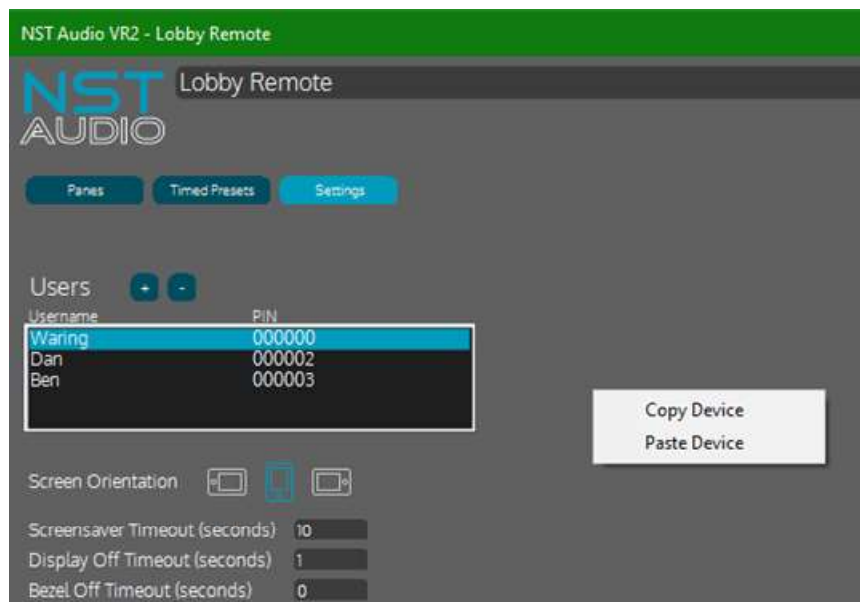

Introduction and Polite Warning

This release of firmware now gives VMO16 devices support for static IP addressing on their Ethernet control ports. This document section assumes the user is familiar with D-Net, our remote control application, and with networking terminology and configurations. It is possible to set a device to a static IP address that will no longer be accessible to D-Net making it impossible to reset without complex reconfiguration of the controlling device, which can be a lengthy process.

We strongly recommend using DHCP IP addressing for NST Audio products unless strictly necessary within your network infrastructure to do otherwise, and do not undertake swapping to static IP addressing during a critical performance!

DHCP and Static IP Addressing Modes

By default, all products leaves the factory in DHCP mode. This means the control network interface will be to get an IP address from a DHCP server. Should a DHCP server not be available it will resort to link local autoconfiguration /automatic private IP addressing mode and auto assign one in the 169.254.*.* range.

For communications between a computer and a device both must have IP addresses in the same range. For example if auto assigned, both must be in the 169.254.*.* range or if obtaining addresses from a DHCP server both in the 192.168.*.* range. Note : 192.168.*.* is just common default range used by many DHCP servers.

Checking a device's IP address in D-Net

After the device has been discovered by D-Net, opening it for editing (double click on device in the left hand rack view) and then selecting the "Settings" tab on VR2 devices will access device operational information, including the device's IP address:

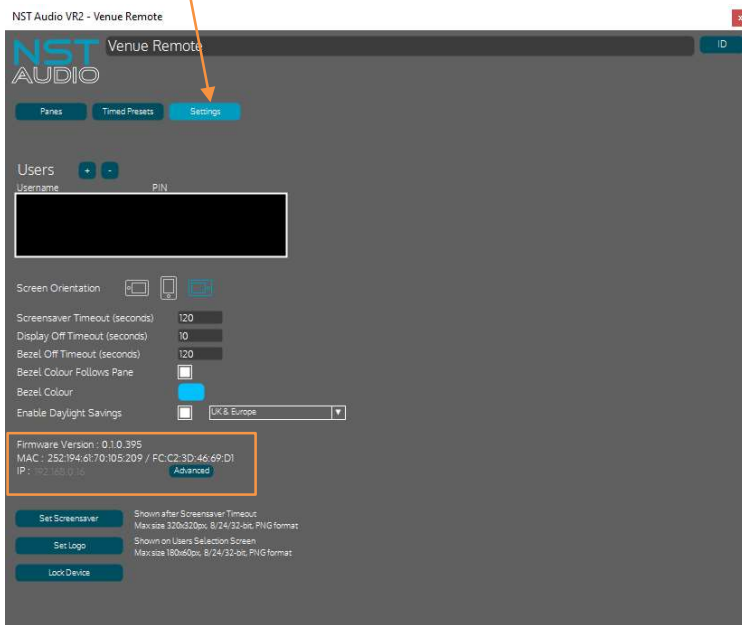

In this instance the device's IP address is set to 192.168.0.20.

The fact that this address is in the 192.169.*.* range means it is probably set to DHCP addressing and not a static IP address. This can be verified by pressing the "Advanced" button.

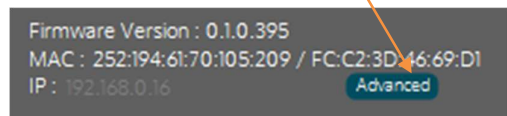

The "Advanced" button then reveals the DHCP status of the device and shows the current subnet mask.

The subnet mask number format is shown in the CIDR format, where the shorthand mask value is appended onto the end of the IP address. This is normally shown in the form 192.168.0.20/16 with the /16 being the subnet mask. It is separated it out in D-Net allowing it to be hidden unless required.

Information

MAC : 252:194:61:33:218:7 / FC:C2:3D:21:DA:07
 Sample Rate : 96000
 Firmware Version : 0.2.0.158
 Message Error Count : 0
 IP : 192.168.0.20
 DHCP
 Subnet Mask 16

[Advanced](#)
[Apply](#)

In our example, set to /16, this equates to an actual subnet mask of 255.255.0.0. Swapping from one format to the other is straightforward - the value in CIDR format is the number of bits shifted in from the MSB of the top octet in the mask.

So, a value of /3 for the subnet mask equates to 11100000.00000000.00000000.00000000 or 224.0.0.0 in decimal.

CIDR	SUBNET MASK
/24	255.255.255.0
/23	255.255.254.0
/22	255.255.252.0
/21	255.255.248.0
/20	255.255.240.0
/19	255.255.224.0
/18	255.255.192.0
/17	255.255.128.0
/16	255.255.0.0
/15	255.254.0.0
/14	255.252.0.0
/13	255.248.0.0
/12	255.240.0.0
/11	255.224.0.0
/10	255.192.0.0
/9	255.128.0.0
/8	255.0.0.0
/7	254.0.0.0
/6	252.0.0.0
/5	248.0.0.0
/4	240.0.0.0
/3	224.0.0.0
/2	192.0.0.0
/1	128.0.0.0
/0	0.0.0.0

Another Polite Warning!

We strongly recommend using DHCP IP addressing for NST Audio products unless strictly necessary within your network infrastructure to do otherwise, and do not undertake swapping to static IP addressing during a critical performance!

Changing a device's IP address in D-Net

Having pressed the "Advanced" button, it is now possible to type in a new IP address for the device and to adjust the value of the subnet mask. Be aware that setting the IP address to something outside of the address space that the computer is using will immediately render it unreachable by D-Net and you will not be able to switch it back.

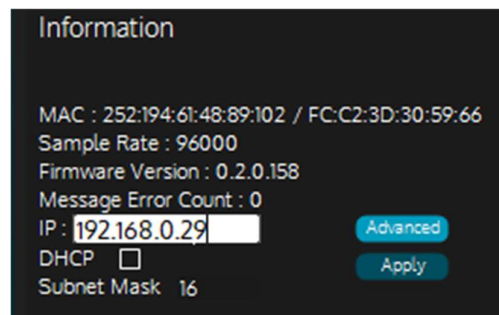

Set the required IP address and press ENTER. Make sure you then press "Apply" to reconfigure the IP address. The device will go offline for a brief period while the network interface resets to use this new address. This will only be for about 1-2 seconds.

Any longer than this, and the IP address chosen is out of the range of the computer. *This is a not immediately recoverable state and restarting D-Net, your computer or the device will NOT fix this!*

If The Worst Has Happened...

A device with an out of range IP address may still be discoverable by your computer and D-Net as the type of messages used for discovery use a different method not tied to the device's IP address. This allows D-Net to find all devices without having to know their individual IP addresses beforehand, and some limited information is returned following a broadcast exchange, including its name, its model and type and its IP address/subnet mask.

D-Net may show a device that is flashing green (connected normally) but primarily red (on a 1-2second cycle). This most likely a device that is out of range. If the device has appeared in D-Net but it will not respond to a Global Mute command while all other devices will, this confirms an out of range IP configuration.

The quickest method to recover the device and reset to a working address space is a direct connection to a PC. The following sections deal with recovering a device to an IP address that is in range, and shows how on both Windows and Mac OS.

IP Address Settings Recovery via Direct Connection

We need to know the IP address and subnet mask on the device that is not responding correctly. If you have been able to discover it in D-Net, double click on device in the left hand rack view and select the "Settings" tab.

In this instance the device's IP address is set to 192.168.0.16.

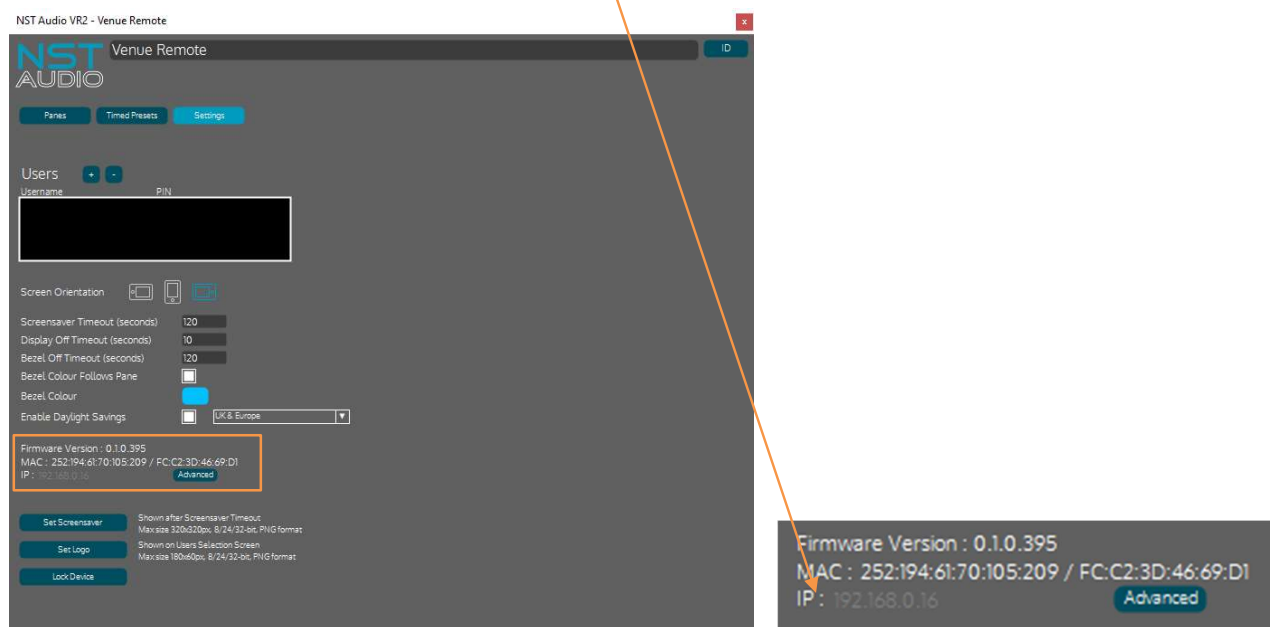

If the device cannot be discovered using D-Net, it can be the VR1 can also show its IP addresses directly on its own screen by accessing the system info pages.

On the VR2 touch screen, press the cog icon, and the IP address is listed here:

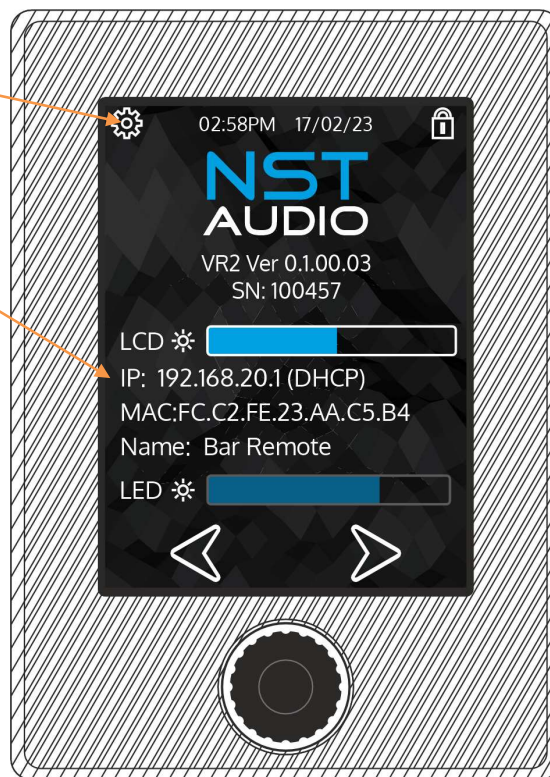

Whichever method is used to obtain the IP address and subnet mask information, the next step is the same. Configuration for a Windows PC starts overleaf and for Mac OS starts on page 38.

Direct Connection to a Computer (Windows)

The next step is to set the computer's wired network IP address to be in a suitable range to allow visibility of the static IP erroneously assigned to the device. This method is largely the same on Windows 10 & 11, and our example shows Windows 10.

Plug an ethernet cable directly into the Comms socket on the rear of the device and into the Ethernet port on the computer. We also recommend temporarily turning off WiFi if in use on the computer.

- 1) Go into Settings > Network & Internet

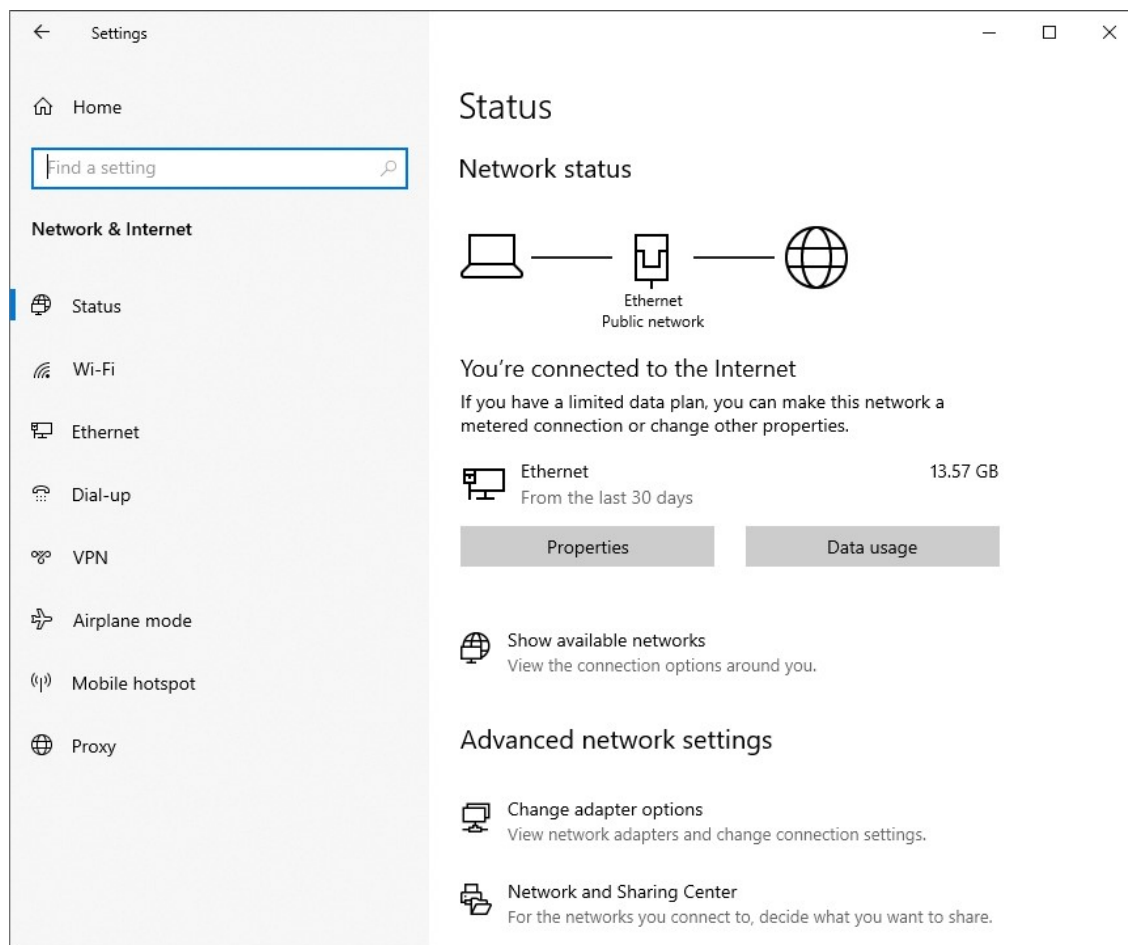

2) Select the Ethernet connection from the left hand list.

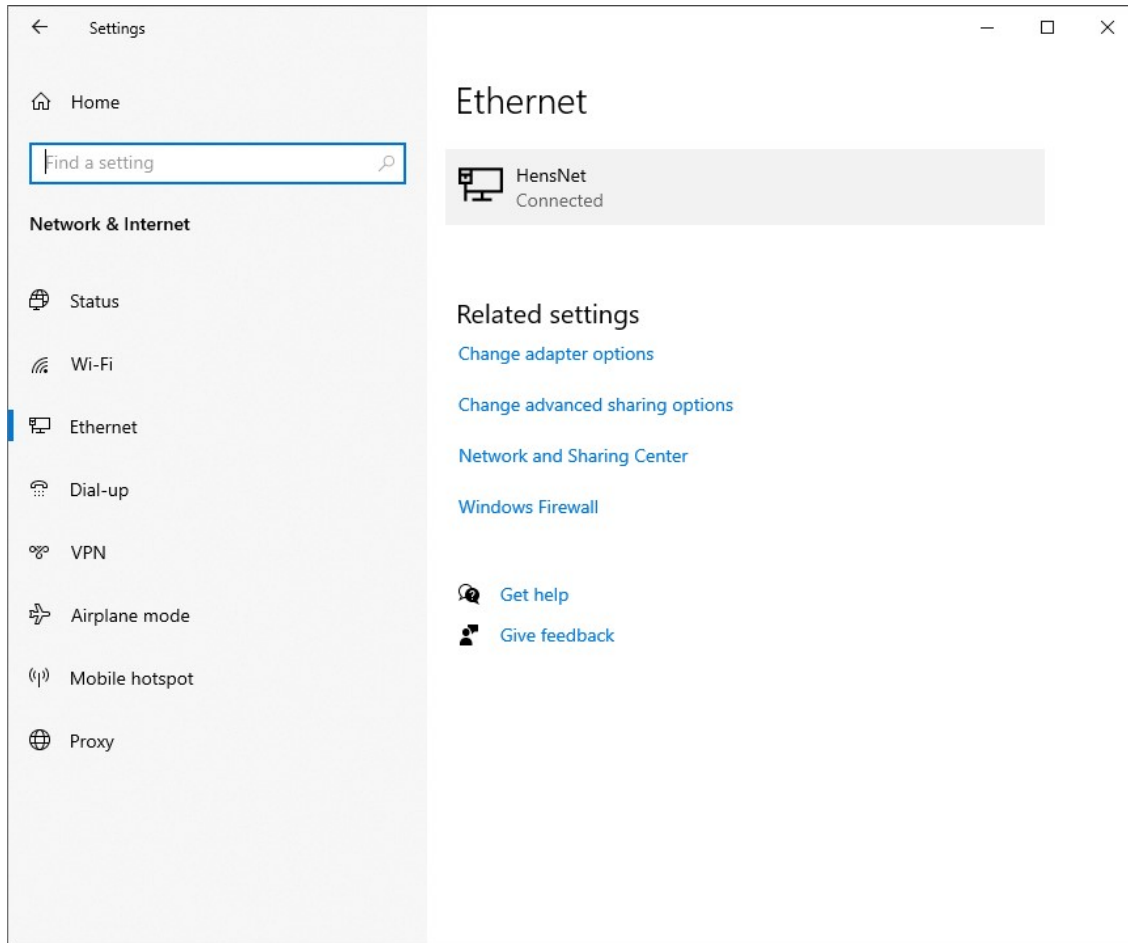

3) Click on the Ethernet network listed (in this example "HensNet").

IP settings are shown towards the bottom of the page. In most instances this will be set to DHCP, as in our case.

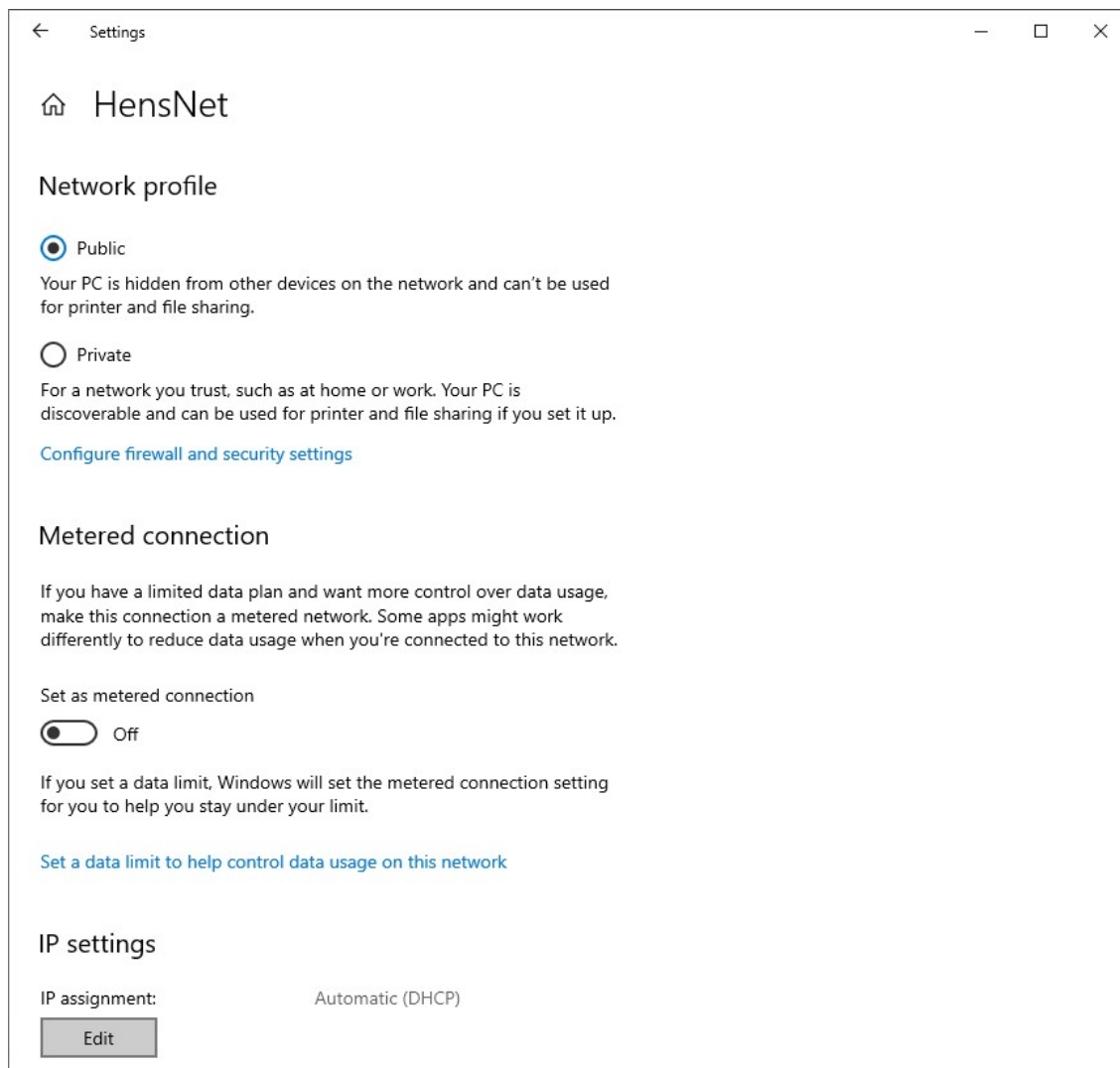

4) Press the Edit button to access the settings.

If set to DHCP, a small window will appear with a drop down list to allow swapping to manual configuration from DHCP.

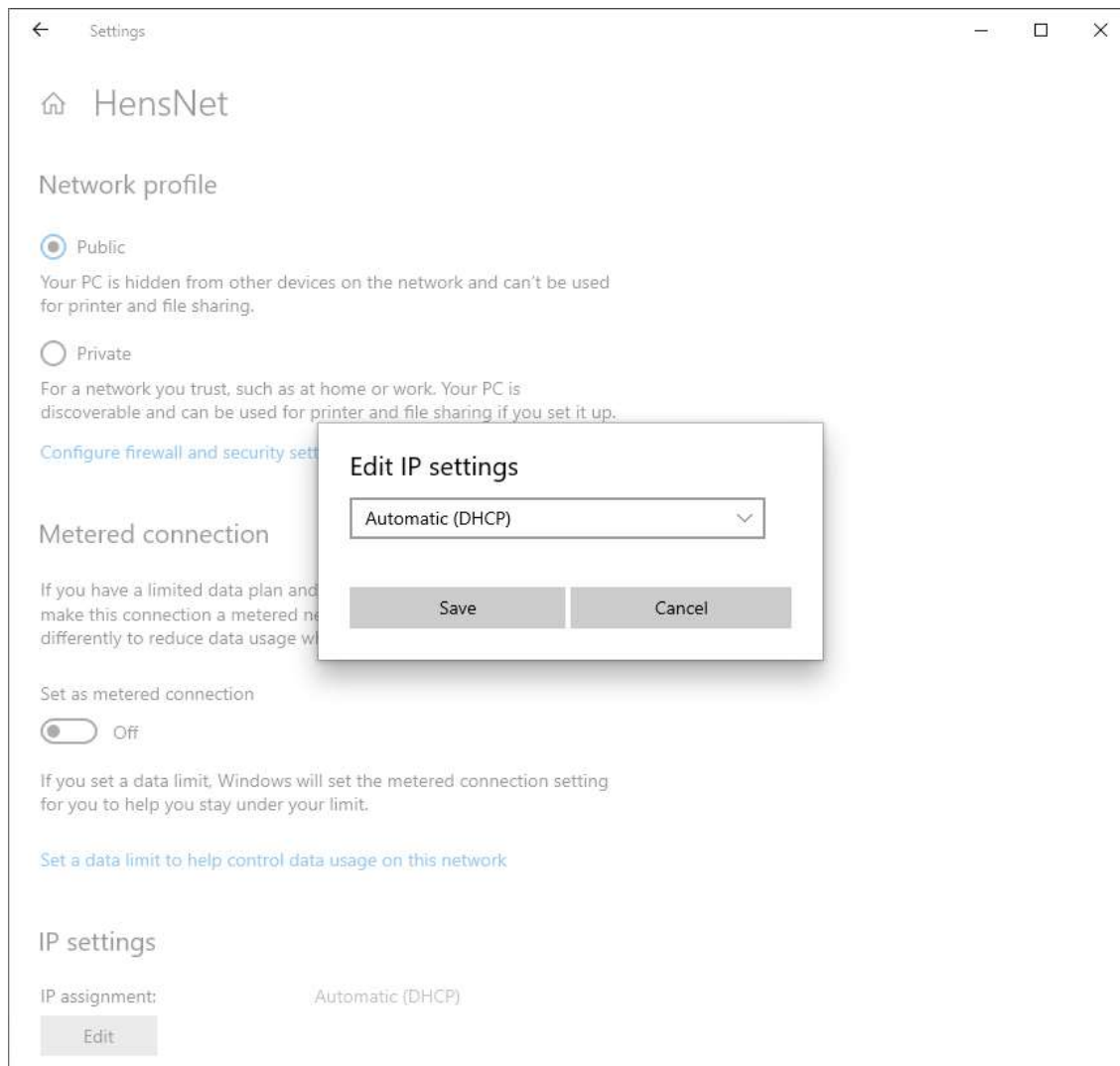

5) Select "Manual" and set the IPV4 switch to "On" to immediately display the manual addressing options.

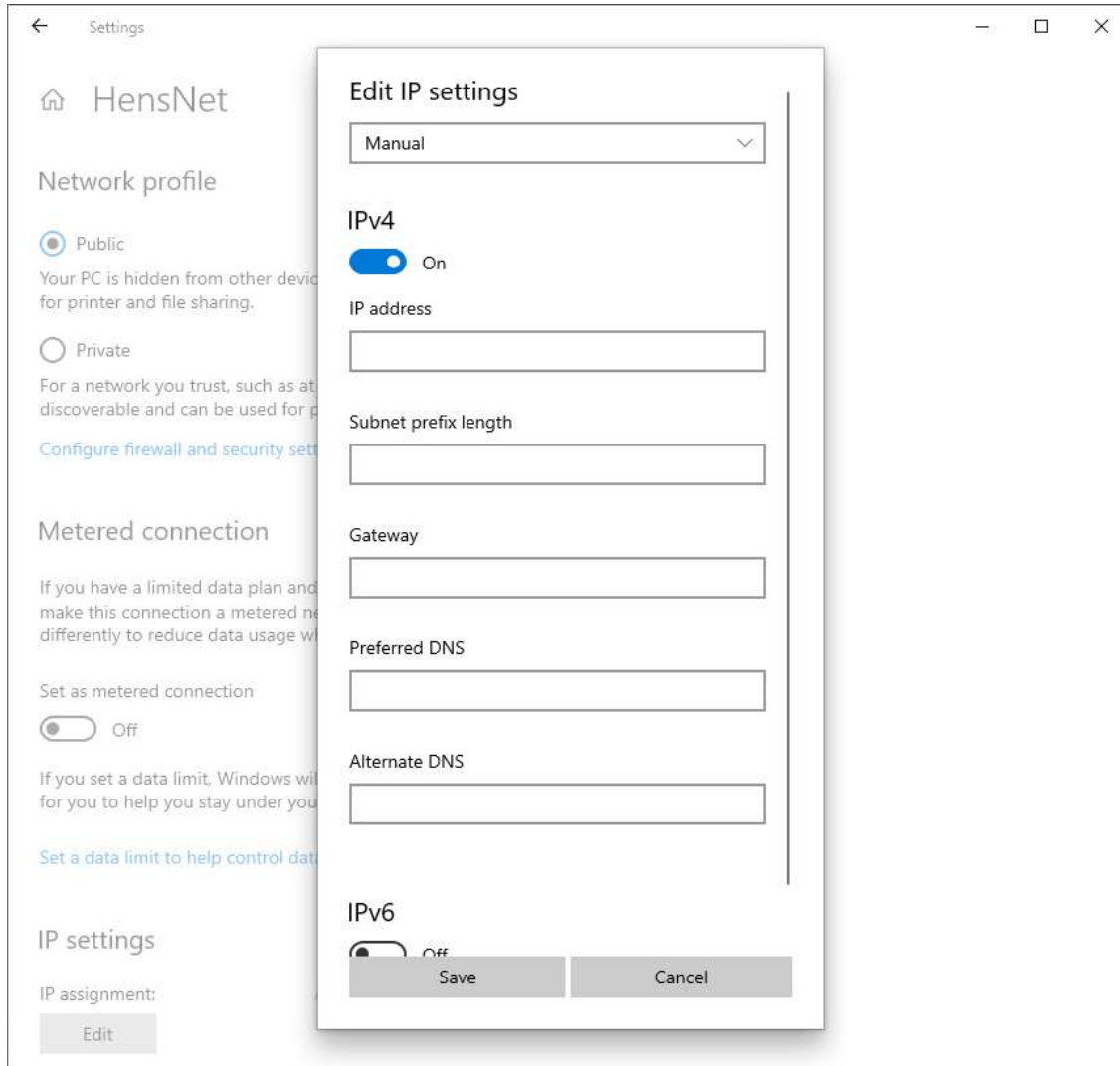

6) Configure the IP address manually.

Based on the IP address and subnet mask of the device, we now populate these settings. Our advice would be to set the IP address to be one less than the device's and the Gateway to one less again. So, if the IP address of the device was 192.168.0.20 and the subnet mask was 16, we would type the following values in:

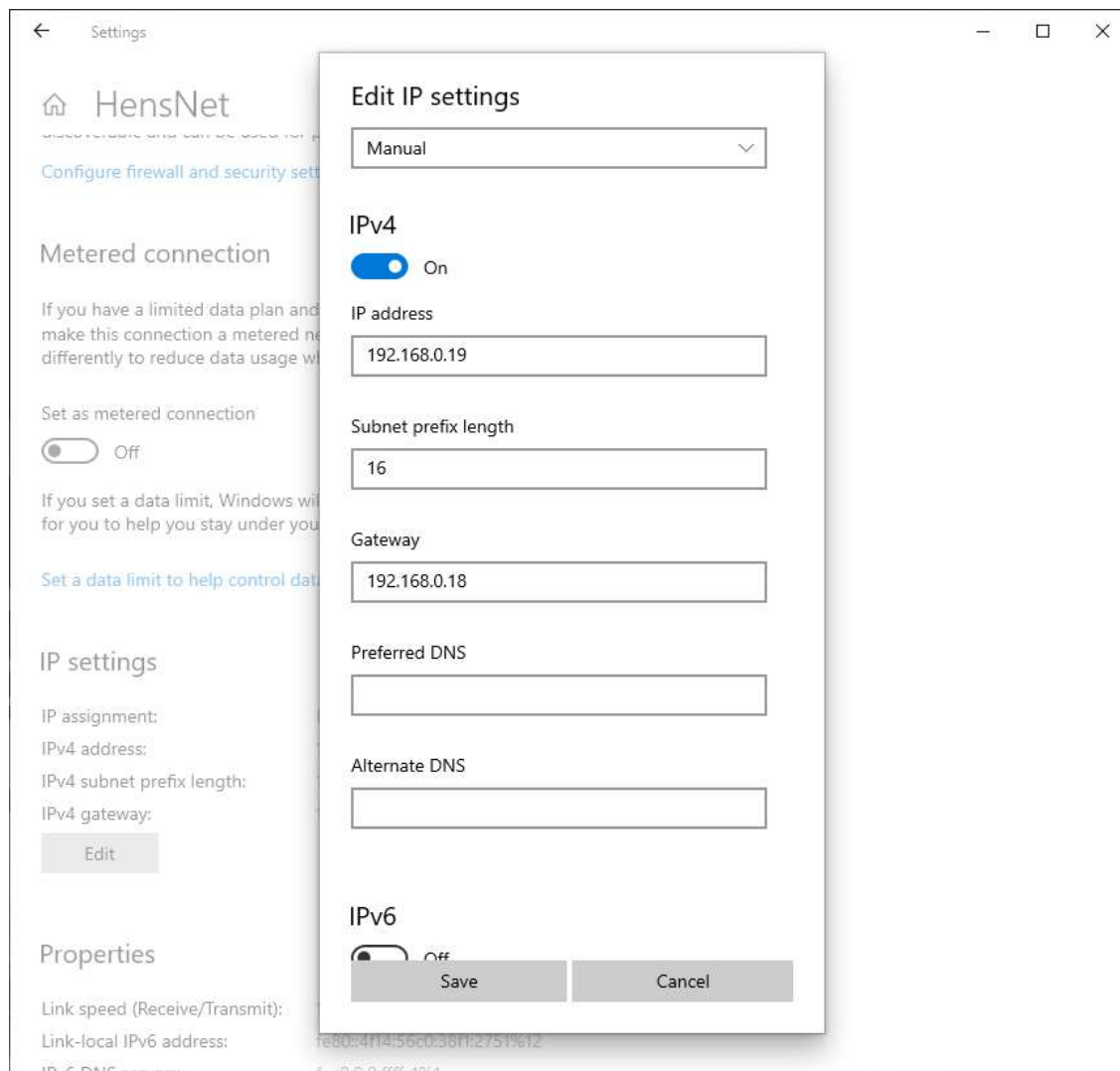

Leave the DNS fields blank. Press "Save" and you're done.

7) Open D-Net and go online.

The device should be discovered and be fully controllable. Test with the Global Mute button and confirm that this is working.

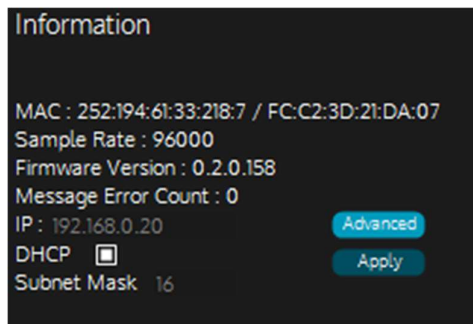

Access the device's IP address settings on the System tab, and press the "Advanced" button. Either set a static IP address in the correct range, or reselect DHCP.

Remember to press "Apply".

The device will most likely go offline now, and you will have to reset your PC's network interface to DHCP (and reconnect it physically to the network, as well as plugging your device back into the network).

8) Reestablish a connection with the device normally on the network.

Once the IP configuration of the computer has been returned to normal, open D-Net once again and go online to confirm that all previous devices are visible as well as the one that has just been reset to DHCP (or the preferred static IP address).

Direct Connection to a Computer (Mac OS)

The next step is to set the computer's wired network IP address to be in a suitable range to allow visibility of the static IP erroneously assigned to the device.

Plug an ethernet cable directly into the Comms socket on the rear of the device and into the Ethernet port on the computer. We also recommend temporarily turning off WiFi if in use on the computer.

- 1) Click on the Apple icon and then System Settings:

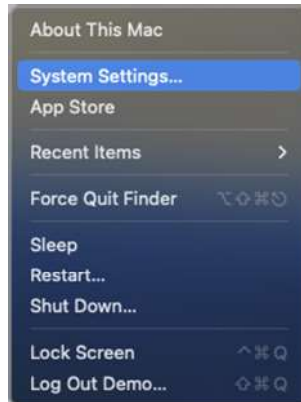

- 2) Open "Network":

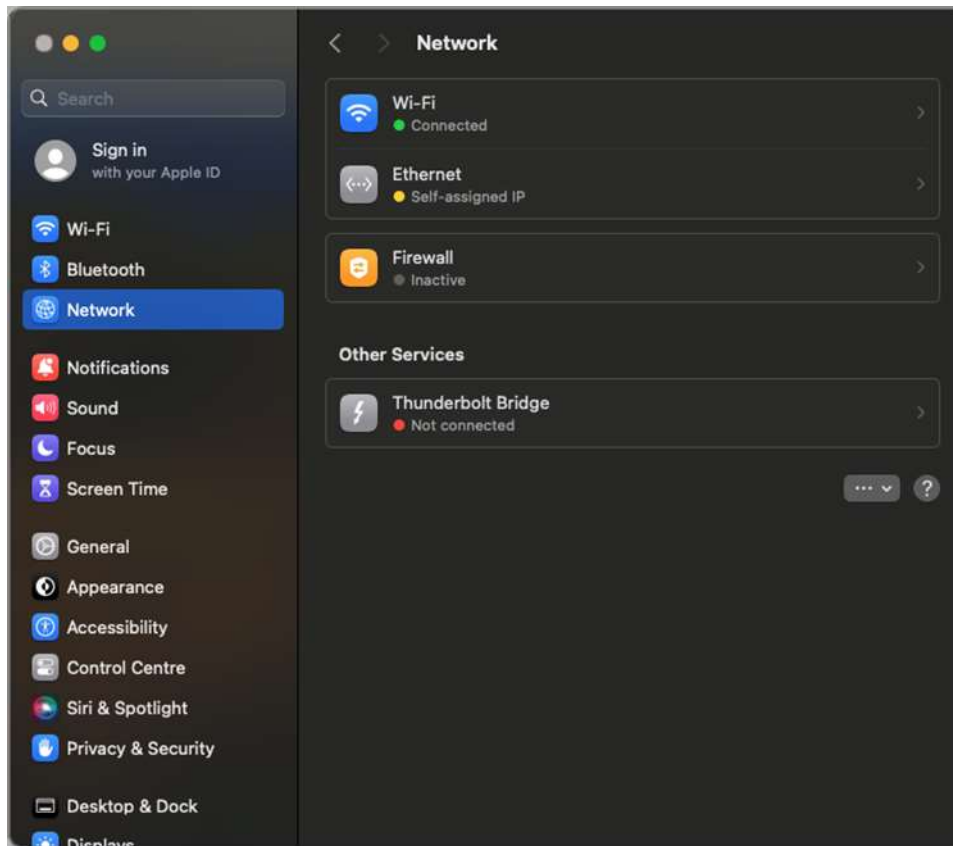

3) Select "Ethernet" and then the "Details" button.

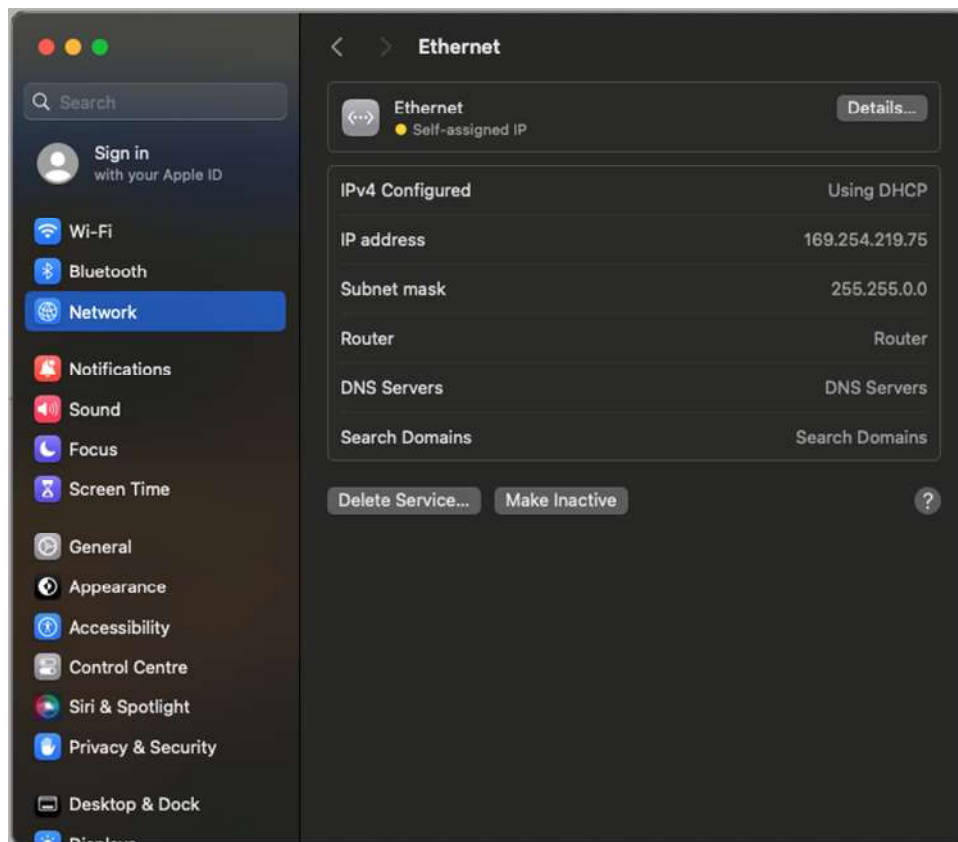

4) In the network settings, select TCP/IP, and select "Manually" from the "Configure IPV4" option.

Our advice would be to set the IP address to be one less than the device's and make sure the subnet mask matches that of the device. So, if the IP address of the device was 192.168.0.20 and the subnet mask was 16, we would type the following values in:

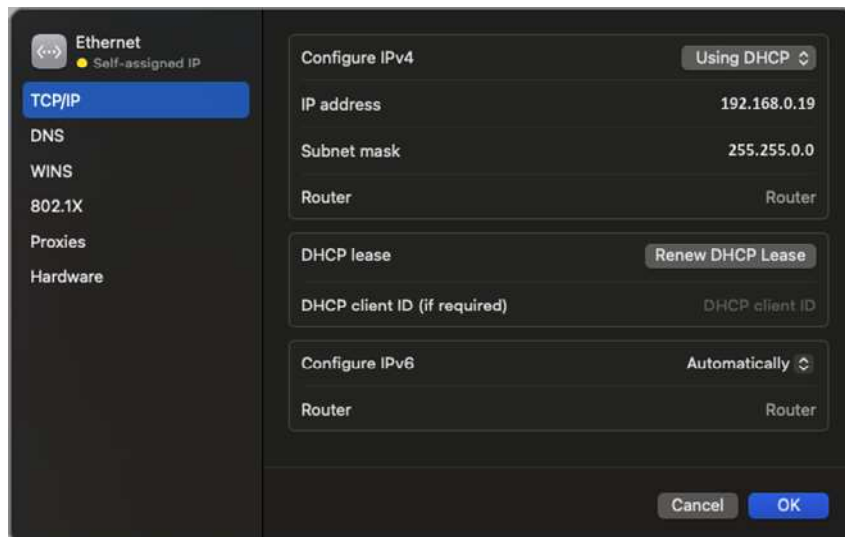

Click OK and you're done.

5) Open D-Net and go online.

The device should be discovered and be fully controllable. Test with the Global Mute button and confirm that this is working.

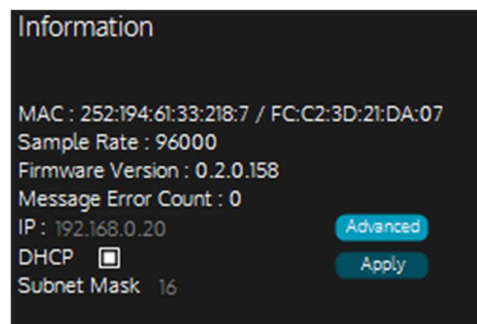

Access the device's IP address settings on the System tab, and press the "Advanced" button. Either set a static IP address in the correct range, or reselect DHCP.

Remember to press "Apply".

The device will most likely go offline now, and you will have to reset your PC's network interface to DHCP (and reconnect it physically to the network, as well as plugging your device back into the network).

5) Reestablish a connection with the device normally on the network.

Once the IP configuration of the computer has been returned to normal, open D-Net once again and go online to confirm that all previous devices are visible as well as the one that has just been reset to DHCP (or the preferred static IP address).

Final notes on the use of static IP addressing

The use of static IP addressing for VM and VR products is only recommended when network infrastructure does not allow DHCP addressing, or where the possibility of the IP address changing could affect operation, such as controlling the devices with third party hardware such as a Q-Sys or Crestron controller.

Note that VR1 and VR2 devices do NOT require the devices they are to control to have static IP addresses. Their addressing of other devices is through a combination of MAC address and device type.

Not having a DHCP server on a network will mean that devices use "link local" addressing and will still operate normally and be controllable with D-Net connected to a simple switch.

What is PoE or Power Over Ethernet?

- PoE is a system that passes electric power, along with data, on standard twisted pair Ethernet cables. This allows a single cable to provide both a data connection and an electric power source, from a PoE capable network router or switch, to VCP devices.

There are lots of standards for PoE – which one do I use?

- The different standards are concerned with the power delivery capability from a single PoE router/switch output – the VR2 is classed as a low power device and will work with all standards – PoE, PoE+, and PoE++. All of these systems run at approx. 48V output.

Where can I purchase a network switch / router with PoE?

- These are very common, and are available from many online shops. They are generally inexpensive and work very well, but we obviously cannot guarantee that every model available will work, so we advise purchasing one from a leading manufacturer (such as Netgear, Belkin, Cisco, TP Link), as we have tested several of these devices, and found they work perfectly.

Do I need special Ethernet cables for PoE use?

- No. Any good quality CAT5 (or greater) standard Ethernet cables will work.

What happens if I accidentally connect a standard Ethernet device to the PoE port?

- Nothing. The electrical power is sent down 'reserved' wires, in the Ethernet cable, that are not normally used and will not be connected, so a PoE port can be used the same as a conventional port.

The VR2 wall panel appears to turn itself off when not being used – Is this normal?

- Yes. The VR2 will go into standby mode, when it is not being used. The device is functioning perfectly normally, and will immediately 'wake-up' when up when the screen is touched. This feature is designed to save power, and also to extend the life of the LCD display and LEDs. Note that the bezel illumination can be left illuminated at half the user set brightness to help locate the device in dark environments and to aesthetically match a venue colour scheme. See page 21 for the explanation of all the customisation options available for the VR2.

How long will the VR2 remember settings if the power is disconnected?

- The VR2 will remember its configurations, user levels and all other settings indefinitely, as these are backed up in non-volatile onboard storage. The real time clock and calendar used for timed presets will be kept alive for a minimum of 2 weeks as long as the VR2 has been powered up for 8+ consecutive hours. If the battery should go flat, the clock will default to 00:00 01/01/00 and timed presets will be disabled.

What do I do if I forget a user's PIN?

- Connect up to D-Net again to gain access to the users set-up for the VR2 and make a note of the user's PIN or change it to something more memorable.

What do I do if I have forgotten the VR2's PIN as I've locked it in D-Net?

- In D-Net go online, connect to the VR2 (even if you can't access it), save the D-Net file on the computer, and email us the file. We can extract the PIN from it.

I've set a static IP address and now I can't see my VR2 in D-Net?

- Unless there's a very good reason to use static IP addressing, we recommend leaving all devices using DHCP IP addressing. You can recover your device by following the instructions starting on page 31 of this manual.

TECHNICAL SPECIFICATIONS

Screen Resolution:

240 x 320px, full RGB

Controls:

Touch screen + 1 x continuous rotary control

Power Requirements:

PoE power only. Load: 3.5W max (backlight and bezel brightness at 100%)

Clock/calendar Backup:

Minimum 2 weeks after continuous charging for 8+ hours

Environmental:

Storage Temperature: -5 °C / 23 °F to 70 °C / 158 °F

Operating Temperature: 0 °C / 32 °F to 50 °C / 122 °F

Maximum Altitude: 2000m

Dimensions:

Height: 112mm (4.4inch), Depth: 25mm (1.0 inches), Width: 80mm (3.2 inches)

Weight:

Net: 220g

Shipping: 280g

MAINTENANCE

The VR2 will require very little routine maintenance. Cleaning the panel surround should only be done with a cloth lightly dampened with water! The use of chemical or abrasive cleaners may damage the finish. Do not use a wet cloth to clean the screen. Do not spray cleaner onto the LCD screen - spray onto cloth and then clean screen if required.

SERVICING

There are no user serviceable parts within the unit!
Please contact us to arrange returning any units to us that require servicing or repairing.

WARRANTY

This product comes with a warranty against defects in components and workmanship only, for a period of five years from the date of shipment to the customer. During the warranty period, NST Audio will, at its discretion, either repair or replace products that prove to be defective, provided that the product is returned, shipping prepaid, to an authorised NST Audio service facility.

Defects caused by unauthorised modifications, misuse, negligence, act of God or accident, or any use of this product that is not in accordance with the instructions provided by NST Audio, are not covered by this warranty.

This warranty is exclusive and no other warranty is expressed or implied.
NST Audio is not liable for consequential damages.

CONTACT

If you have any questions or comments about the information contained within this manual, or require further assistance, then please do not hesitate to contact us:



www.nstaudio.com



support@nstaudio.com



www.facebook.com/nstaudio



www.instagram.com/nstaudio

Thank you!

NST
AUDIO

The NST Audio team